

Valves for geothermal power plants

Flash Steam Power Plant

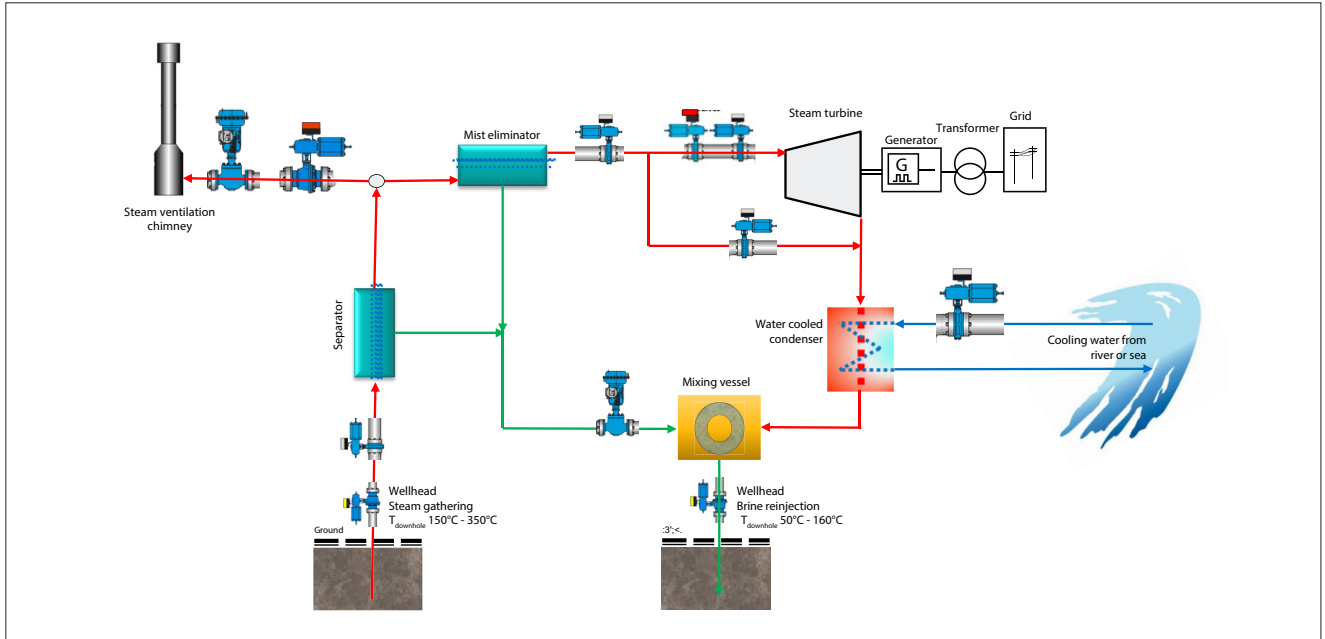

Binary Cycle Power Plant

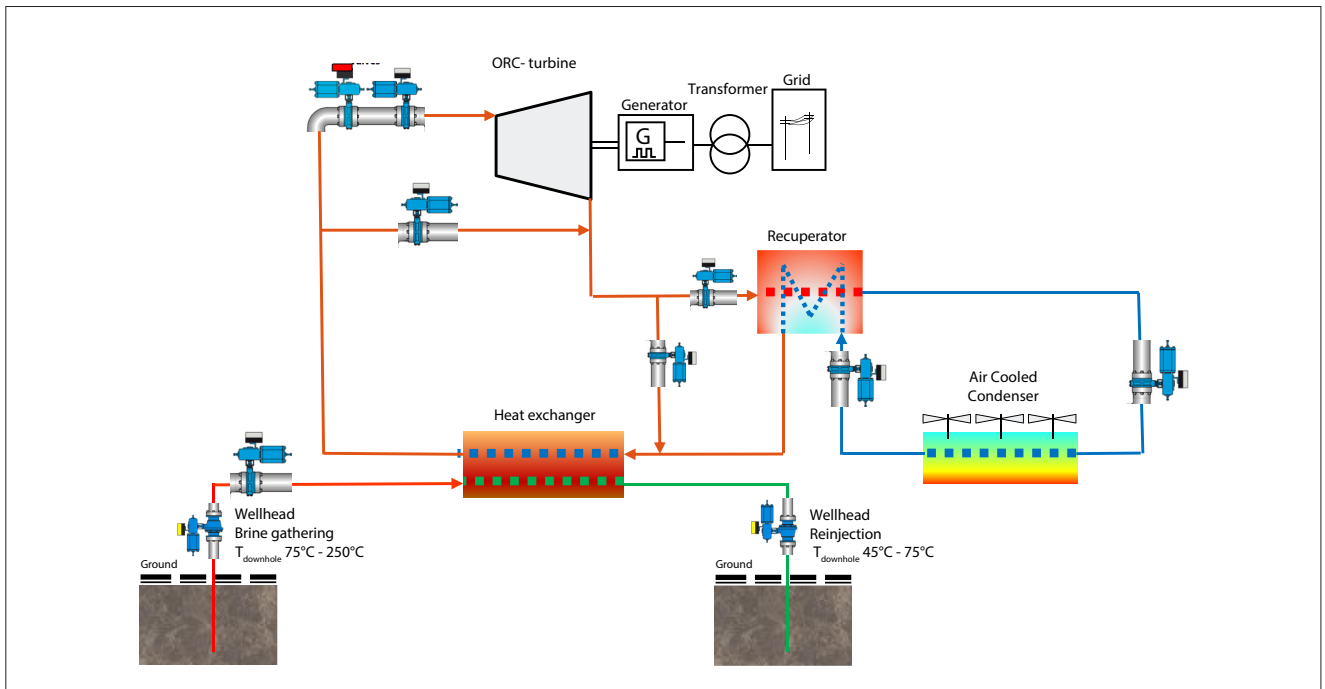

Process overview

Geothermal energy is a clean and renewable source. There are 3 different processes applied to transform the geothermal energy to electric energy. Dry-Steam, Flash-steam and Binary Cycle technology. Today, depending from the state (steam or brine) and temperature of the geothermal fluid, only Flash-steam or Binary Cycle technology are applied.

Flash Steam Geothermal Power Plant

Flash steam power plants run the turbine with the steam, coming from the ground. But before the geothermal steam enters the turbine extensive purification is necessary to protect the turbines, pumps and other components. Typically, the geothermal steam contains silica, sand and other abrasives. Those particles are removed in scrubbers and separators. To increase the efficiency, the wet part of the steam is removed with a mist eliminator. After the steam have left the turbine and its energy is transformed to electricity, it will be cooled and reinjected to the ground.

Binary Cycle Geothermal Power Plant

Binary cycle technology is applied, if the fluid from the ground does not contains enough steam to run a turbine. This is a case with steamy brine. Often this steamy brine has got enough energy to generate electricity by heating a second fluid. This is a fluid with low boiling point, e.g. Isopentane or R134a and flows through a closed-loop system. There are 2 technologies of these systems, Kalina cycle and Organic-Raking cycle (ORC), while the latter one is the most applied. The ORC cycle includes the heat exchanger, where the 2nd fluid gets vaporized, the turbine and the condenser where the fluid becomes liquefied. To increase the efficiency the system includes also a recuperator.

Challenges

Scaling and media solids

The steam or the brine coming from the boreholes can be very abrasive. The loosened soil from the ground confront the valves with erosion and clogging. Valves need to overcome the presence of solids while still being able to accurate control capabilities.

All safety valves must work reliable with the difficult media at any time.

Subject to change without prior notice.

Neles, Neles Easyflow, Jamesbury, Stonel, Valvcon and Flowrox, and certain other trademarks, are either registered trademarks or trademarks of Valmet Oyj or its subsidiaries in the United States and/or in other countries.

For more information www.neles.com/trademarks

Valmet Flow Control Oy

Vanha Porvoontie 229, 01380 Vantaa, Finland.

Tel. +358 10 417 5000.

www.valmet.com/flowcontrol

High energy exploitation

Any waste of energy needs to be minimized in order to optimize the efficiency. Low pressure drops within the valves are required, meaning valve's flow capacity per size should be maximized.

Expectation to an optimal process orientated fast reacting controllability to optimize the complete loop to operate the turbine most efficiently.

Neles solutions

Knowing geothermal applications

Given the breadth and sophistication of our Neles™ and Jamesbury™ product brands, we are able to be a single-source supplier of control and on-off valves for geothermal plants. Our butterfly, globe, segment and ball valves range from 1" up to 60".

At the wellhead, control valves, such as Neles Finetrol™ and Segment valves are in wide use by many customers at the drill hole exits. On the steam and ORC-turbine side, Neles' soft seated Jamesbury Wafer-Sphere™ valves and Neles metal seated triple eccentric disc valves are commonly applied.

We have considerable experience helping customers to size and select the right valves for geothermal service. The Nelprof™ valve selection software is also available to help engineers with valve sizing and calculating calculate flow characteristics. Once in service, Asset Management software helps to carry out predictive maintenance with live monitoring of the valve performance.

Benefits

High performance, reliability and control accuracy

We offer accumulated knowledge gained through experience from many geothermal power plants in EU, Iceland, Turkey, Mexico, USA, Indonesia and Kenya. Reliable valve solutions featuring high control performance and control accuracy play a significant role in extracting geothermal energy from the heat of the Earth.

Using Valmet as the sole supplier of flow control technologies helps our customers to reduce spare parts inventory and maintenance costs while also mitigating the stress of procurement and commissioning.

