

Neles™ Angle pattern globe valves

Series AU, AB, AM

Installation, maintenance and
operating instructions

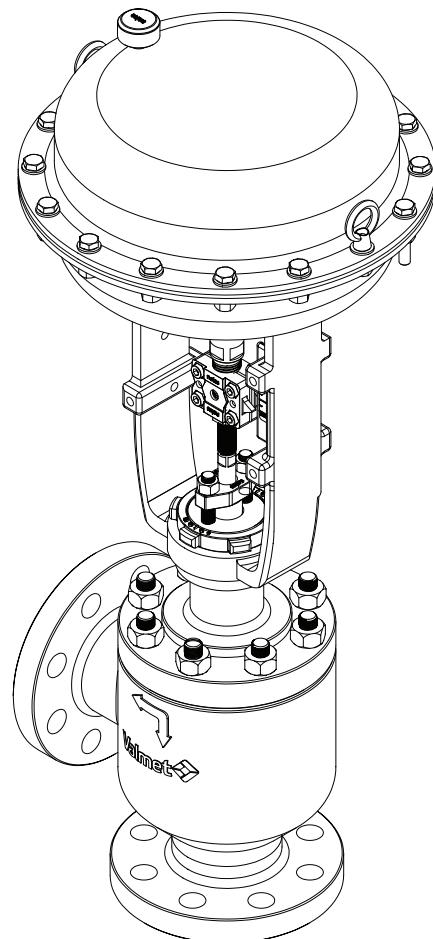

Table of contents

GENERAL	3	TOOLS	16
Scope of the manual	3	ORDERING SPARE PARTS	16
Valve construction	3	EXPLODED VIEW AND PARTS LIST	17
Valve markings	3	DIMENSIONS AND WEIGHTS	20
Technical specifications	3	Valve AU, AB, AM	20
Valve seat leakage class	3	Actuator VDD/VDR	22
Recycling and disposal	4	Actuator VBD/R	24
Safety precautions	4	Actuator VBC	25
TRANSPORTATION, RECEPTION AND STORAGE	5	Actuator VBC with volume chamber	26
VALVE INSTALLATION	5	Actuator VCC without handwheel	27
General	5	Actuator VCC with handwheel	28
Installation into the pipeline	5	EU DECLARATION OF CONFORMITY FOR ATEX APPROVED VALVES	29
Hydrostatic testing and line flushing	6	TYPE CODE	30
Control valve assembly	6	GENERAL SAFETY WARNINGS AND DISCLAIMERS	36
Valve insulation	6	General safety warnings	36
MAINTENANCE	6	General disclaimers	36
General	6		
Gland packing adjustment & bellows seal	6		
Replacing the gland packing	7		
Replacing the general trim and body reassembly	10		
Pilot balanced plug	10		
High temperature graphite seal trim	11		
High temperature metal seal trim	11		
TESTING THE VALVE	12		
REMOVAL & MOUNTING THE ACTUATOR	15		

Subject to change without notice.

All trademarks are property of their respective owners.



This product meets the requirements set by the Customs Union of the Republic of Belarus, the Republic of Kazakhstan and the Russian Federation.

READ THESE INSTRUCTIONS FIRST!

These instructions provide information about safe handling and operation of the valve.

If you require additional assistance, please contact the manufacturer or manufacturer's representative.

SAVE THESE INSTRUCTIONS!

Addresses and phone numbers are printed on the back cover.

1. GENERAL

1.1 Scope of the manual

This manual provides essential information on series 'A', AU: Angle pattern-Unbalanced single seated, AB: Angle pattern-Balanced single seated, AM: Angle pattern-Omega multistage trim installed sliding stem valves. Actuators and positioners are only discussed briefly. Refer to the individual manuals for further information on their installation, operation and maintenance.

NOTE:

Selection and use of the valve in a specific application requires close consideration of detailed aspects. Due to the nature of the product, this manual cannot cover all the individual situations that may occur when the valve is used.

If you are uncertain about use of the valve or its suitability for your intended purpose, please contact Valmet for more information.

For valves in oxygen service, please see also the separate installation, maintenance and operating instructions for oxygen service (see Neles document id:10O270EN.pdf).

1.2 Valve construction

Series AU, Angle-Unbalanced valves are flanged (weld end available) single seated sliding stem control valves. The valve seat ring and retainer and plug with stem is a module accessible through the bonnet opening (top entry) of the body.

The standard design provides a top guide with a contoured plug with a quick change seat ring. The solid top (retainer) plug boss guiding makes strong support to ensure valve alignment.

This series are available to provide a series of reduced bore trim and the standard seat tightness is class IV, optional trims can meet to class V and VI, ANSI/FCI 70.2.

Series AB, Angle-Balanced cage guide valves are flanged (weld end available) single seated sliding stem control valves.

The valve seat ring and cage and plug with stem is a module accessible through the bonnet opening (top entry) of the body.

The standard design provides a cage guide with a piston type plug with a quick change seat ring. The two split cages and inserted plug seal ring makes strong support to ensure valve alignment.

This series is available with series of reduced Cv trims and the standard seat tightness is class III-IV, optional trims can meet to class V, ANSI/FCI 70-2.

Series AM, Angle-Omega, multistage trim installed valves are flanged (weld end available) single seated sliding stem control valves.

The valve seat ring and cage and plug with stem is a module accessible through the bonnet opening (top entry) of the body.

The standard design provides a cage guide with a piston type plug with a quick change seat ring. The two split cages (cage guide and cage) and inserted plug seal ring makes strong support to ensure valve alignment.

For few cases in very small rated Cv, applicable unbalanced contoured trim in this series.

This series is available with series of reduced Cv trims and the standard seat tightness is class III-IV, optional trims can meet to class V, ANSI/FCI 70-2.

The detailed structure is revealed by the type code shown on the valve identification plate. The type code is explained in Section 11.

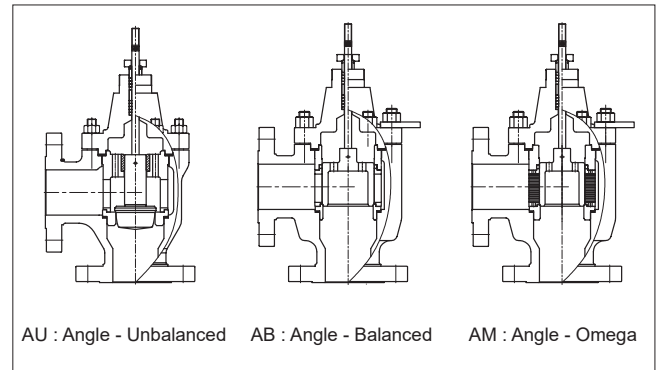

Fig. 1 Construction of a Neles 'A' series single seated valve

1.3 Valve markings

The body markings are: manufacturer's trademark, nominal size, pressure rating and material of the body. The identification plate is attached on an actuator yoke side, see Fig. 2.

Markings on the identification plate:

1. Type designation (Valve code)
2. Size, Rating
3. Cv
4. Body material
5. Plug, Stem material
6. Seat material
7. Temp. min./max.
8. Maximum (shut-off) pressure
9. Valve manufacturing date
10. Tag No.
11. CO No.

1.4 Technical specifications

Face-to-face length:	ANSI/ISA-75.08.01, 03, 05 & ANSI/ISA-75.08.06 (Long)
Body rating:	Class 150 to Class 2500 PN 10 to PN 320
Max. pressure differential:	acc. to pressure class
Temperature range:	-196° to +593 °C (depending on the body materials and bonnet type)
Flow direction:	indicated by an arrow on the body (normally flow to open)
Actuator mounting:	threaded bonnet with yoke nut or bolted yoke
Stem connection:	clamp with bolts/nuts
Dimensions:	see Section 10
Weights:	see Section 10

Note that the max. shut-off pressure is based on the mechanical maximum differential pressure at ambient temperature. You must always observe the fluid temperature when deciding on applicable pressure values. When selecting a valve you must also check the noise level, cavitation intensity, flow velocity, actuator load factor, etc. using Nelprof.

1.5 Valve seat leakage class

The valve follows the seat leakage classifications of ANSI/FCI 70-2 requirement.

1.6 Recycling and disposal

Most valve parts can be recycled if sorted according to material. Most parts have a material marking. A material list is supplied with the valve. In addition, separate recycling and disposal instructions are available from the manufacturer. A valve can also be returned to the manufacturer for recycling and disposal for a fee.

1.7 Safety precautions

CAUTION:

Do not exceed the valve performance limitations!

Exceeding the limitations marked on the valve may cause damage and lead to uncontrolled pressure release. Damage or personal injury may result

CAUTION:

Do not dismantle the valve or remove it from the pipeline while the valve is pressurised!

Dismantling or removing a pressurised valve will result in uncontrolled pressure release. Always isolate the relevant part of the pipeline, release the pressure from the valve and remove the medium before dismantling the valve.

Be aware of the type of medium involved. Protect yourself and the environment from any harmful or poisonous substances. Make sure that no medium can enter the pipeline during valve maintenance.

Failure to do this may result in damage or personal injury.

CAUTION:

Be aware of plug motion!

To avoid personal inquiries resulting from movement of a plug, keep any part of your body, especially fingers out of the flow port. Any tools or any other foreign stuff also must be kept out of this flow ports.

During valve maintenance, make sure that air pressure supply line is disconnected to the actuator.

Failure of this may cause personal inquiry and product damage.

CAUTION:

Protect yourself from noise!

The valve may produce noise in the pipeline. The noise level depends on the application. It can be measured or calculated using the Neles Nelprof software. Observe the relevant working environment regulations in terms of noise emission.

CAUTION:

Beware of a very cold or hot valve!

The valve body may be very cold or very hot during use. Protect yourself against cold injuries or burns.

CAUTION:

When handling the valve or the control valve assembly, take its weight into account!

Never lift the valve or control valve assembly by the positioner, the limit switch or their piping.

Place the lifting ropes securely around the valve body (see Fig. 2). Damage or personal injury may result from falling parts.

CAUTION:

Follow the proper procedures when handling and servicing Oxygen valves.

CAUTION:

Hexavalent chromium(VI) or Cr(VI), is known to cause cancer. Be sure to use all appropriate personal protective equipment (PPE) when welding metals containing chromium.

CAUTION:

Ensure that any weld splatter does not fall onto the valve trim. This may prevent proper trim movement or damage critical seating surfaces causing leaks.

CAUTION:

Make sure the valve is not pressurized when removing the actuator.

CAUTION:

Potential electrostatic charging hazard. Ensure the protection in the process.

CAUTION:

Improper stud and nuts or any other parts are not to be used. Use of unapproved stud and nuts or any other parts may cause an accident which results in personal inquires and property damage.

2. TRANSPORTATION, RECEPTION AND STORAGE

Check the valve and the accompanying devices for any damage that may have occurred during transport.

Store the valve carefully before installation, preferably indoors in a dry place.

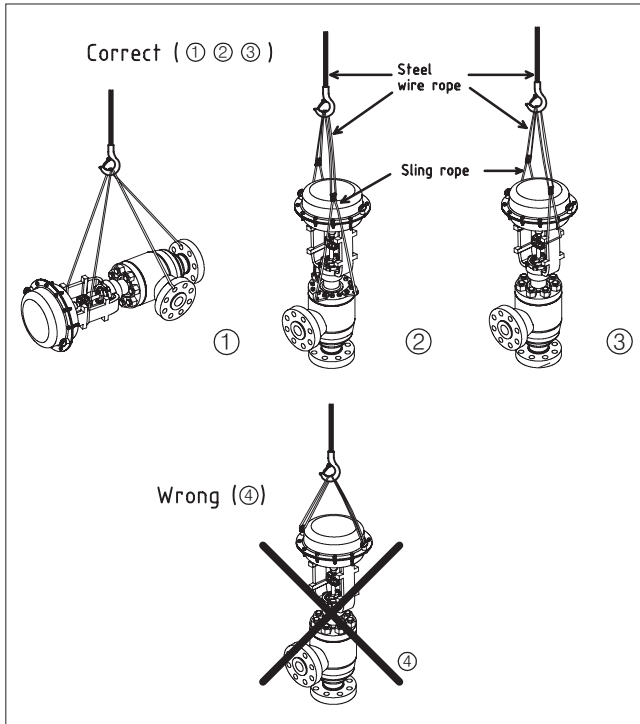

Fig. 2 Lifting the valve

Do not remove the flow port protectors until immediately before installation of the valve into the pipeline.

The valve is delivered in the closed position. Valve equipped with a spring-return actuator is delivered in the position determined by the spring.

3. VALVE INSTALLATION

3.1 General

Remove the flow port protectors and check that the valve is clean inside.

CAUTION:

When handling the valve or the control valve assembly, take its weight into account!

NOTE:

Heat insulation should be installed when valve design temperature is over 260°C to protect actuator, positioner and accessories from heat.

3.2 Installation into the pipeline

Pipeline cleaning

Make sure no foreign particles, such as sand or pieces of welding electrode, are in the pipeline, they may damage the sealing surfaces.

Installation valve

The valve has an arrow indicating the flow direction. Install the valve in the pipeline so that the flow direction of the valve corresponds to the flow direction marked on the pipe.

The mounting orientation of the valve should be vertical position as it is shown on Fig. 3.

CAUTION:

Hexavalent chromium(VI) or Cr(VI), is known to cause cancer. Be sure to use all appropriate personal protective equipment (PPE) when welding metals containing chromium.

CAUTION:

Ensure that any weld splatter does not fall onto the valve trim. This may prevent proper trim movement or damage critical seating surfaces causing leaks.

NOTE:

For any other mounting position, please consult the factory.

Choose flange gaskets according to the operating conditions.

Do not attempt to correct a pipeline misalignment by means of flange bolting.

Loads on the valve body from pipeline vibrations can be reduced by supporting the pipeline properly. Reduced vibration also increases the lifetime of the positioner.

Where necessary, you can support the valve by the body, using regular pipe clamps and supports. Do not fasten supports to the valve or flange bolting or to the actuator, see Fig. 3.

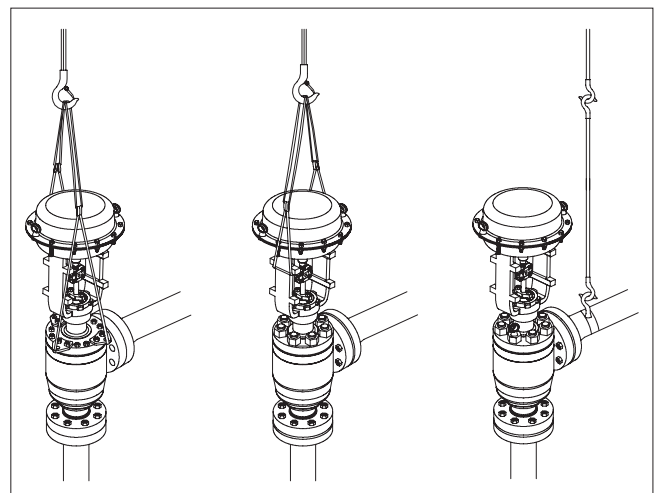

Fig. 3 Installing the control valve into pipeline using supports

Do not attempt to correct a pipeline misalignment by means of flange bolting.

Loads on the valve body from pipeline vibrations can be reduced by supporting the pipeline properly. Reduced vibration also increases the lifetime of the positioner.

Where necessary, you can support the valve by the body, using regular pipe clamps and supports. Do not fasten supports to the valve or flange bolting or to the actuator, see Fig. 3.

3.3 Hydrostatic testing and line flushing

When performing the hydrostatic test and flushing on the line, the control valve should not be used as an isolating valve. Ensure that the control valve is always in the open position before starting this process; otherwise, it may lead to valve and trim damage or failure of the seals. Flushing and hydrostatic test kits can be purchased from Valmet.

3.4 Control valve assembly

Check all joints, piping and cables.

Check that the actuator stop screws, positioner and limit switches are calibrated. Refer to their installation, maintenance and operating manuals.

3.5 Valve insulation

If necessary, the valve may be insulated. Insulation must not continue above the upper level of the valve body, see Fig. 4.

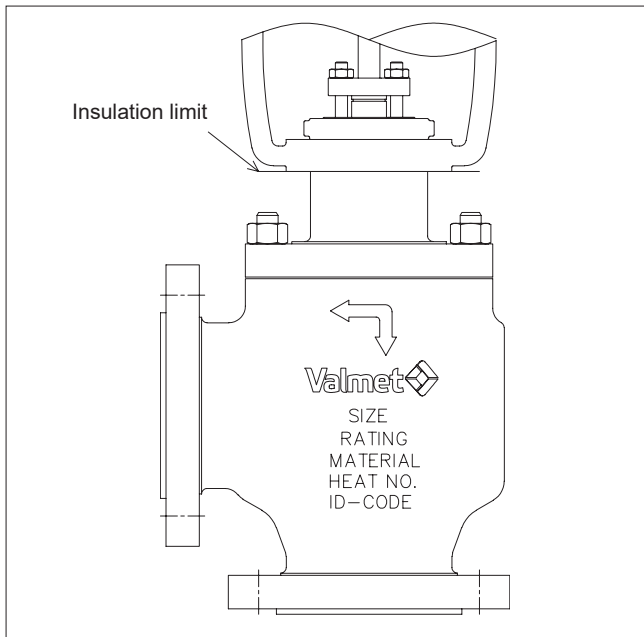

Fig. 4 Insulation of the valve

4. MAINTENANCE

CAUTION:

Observe the safety precautions listed in Section 1.7 before starting work!

CAUTION:

When handling the valve or the control valve assembly, take its weight into account!

4.1 General

The Neles 'A' series angle valves require no regular maintenance. However, check the gland packing for leakage. This section outlines the maintenance that can be carried out by the user.

The numbers in parentheses refer to the parts lists and the exploded views of the valve in Section 9.

NOTE:

If you send the valve to the manufacturer for repair, do not dismantle it. Clean the valve carefully, including the inside. For safety reasons, inform the manufacturer of the nature of the medium when you send the valve.

NOTE:

Always use original spare parts to make sure the valve functions as intended.

4.2 Gland packing adjustment & bellows seal

In the event of a packing leakage tighten the hexagon nuts (18) in ¼ turn steps each until the leakage is stopped. Do not tighten more than necessary.

NOTE:

In case of the bellows seal bonnet construction, the gland packings are installed up at the top of the bellows bonnet (8L).

CAUTION:

Bellows assembly(8M) is welded with a the plug set. The bellows assembly should not be twisted.

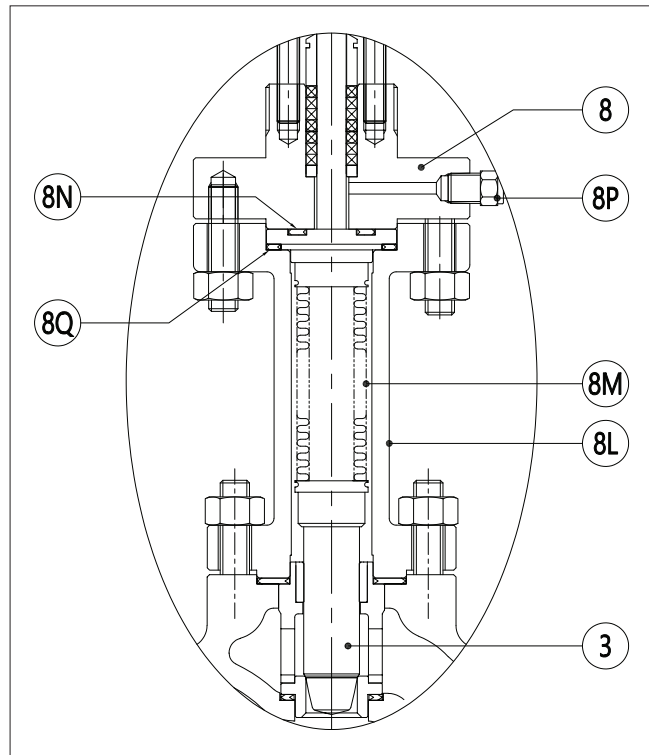

Fig. 5 Bellows seal construction (Bellows unbalanced trim)

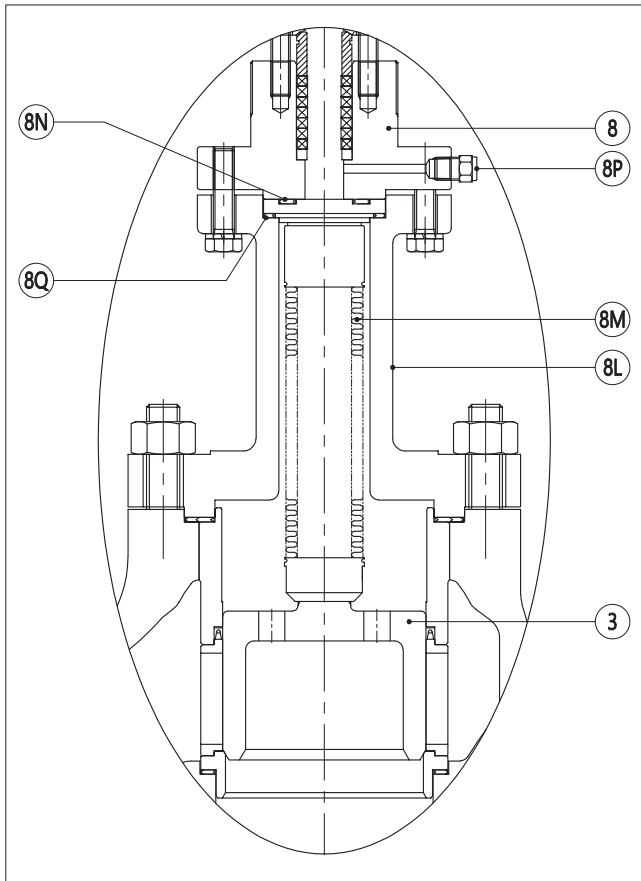

Fig. 6 Bellows seal construction (Bellows balanced trim)

CAUTION:

The bellows seal valve will be shipped from the factory with the plug (8P) inserted into the monitoring port. Customers should connect their leakage detection system to this monitoring port to receive warnings in the event of a bellows seal leakage.

4.3 Replacing the gland packing

CAUTION:

Do not dismantle the valve or remove it from the pipeline while the valve is pressurised!

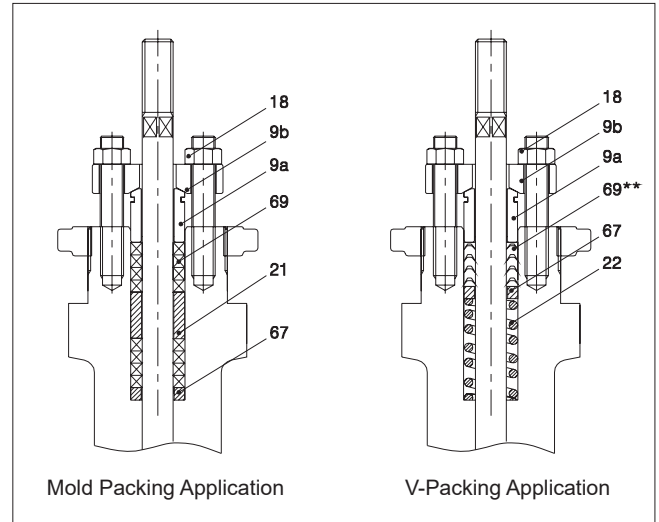

Fig. 7 Gland packing

- Make sure the valve is not pressurised.
- Remove the actuator from the valve stem according to the instructions given in the actuator manual.
- Loosen and remove the hexagon nuts (18).
- Remove the gland flange (9b), and gland (9a) up to the valve stem.
- Remove the old packing rings (69) using a pointed tool, avoid damaging the seal surfaces and valve stem.
- Clean the packing ring counterbore.
- Mount the new packing rings one by one into the packing gland box using the gland as a tool and mount the gland with hand-tightened nuts.
- Each packing ring (69) shall be firmly seated into the stuffing box using the packing tamping tool.
- Fasten the gland with the hexagon nuts (18) and tighten them.
- Check leakage when the valve is pressurised.

CAUTION:

Be careful when using a hammer.

- Joints of successive braided type packing rings (69 & 69a if applicable) must be inserted 180 degrees against the previously inserted packing rings (69 & 69a if applicable).
- Apply lubricant which is suitable for the process type and temperature to the inner surface of the packing rings excluding PTFE packing and emission packing. (69)(& 69a if applicable). However, lubricant is not allowed for oxygen service or in any processes with temperature higher than 260°C(550°F).
- Apply lubricant suitable for process temperature to the gland studs (14) and nuts (18) properly. However, lubricants for special services which are flammable should not be used.

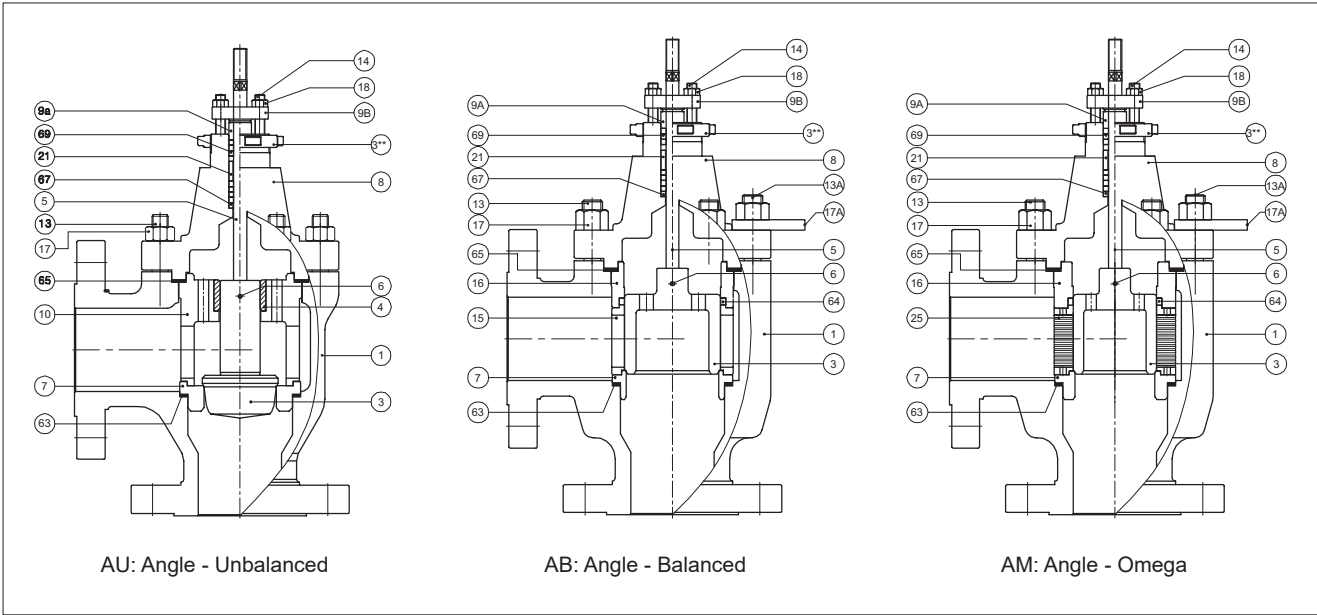

Fig. 8 Neles 'A' Series Angle Pattern - Globe Valves

Table 1 Required torques for bonnet nuts

Valve Size		Rating (ANSI)	Bonnet Stud Bolts		Required Torques (±5% allowable)	
mm	in		Size	Q'ty	Nm	lbf ft
25	1	150-300	1/2"-13UNC	4	45	33
		600	1/2"-13UNC	4	45	33
		900	7/8"-9UNC	8	250	184
		1500	7/8"-9UNC	8	250	184
		2500	1-1/8"-8UN	8	560	413
40	1.5	150-300	1/2"-13UNC	4	45	33
		600	1/2"-13UNC	4	45	33
		900	7/8"-9UNC	8	250	184
		1500	7/8"-9UNC	8	250	184
		2500	1-1/8"-8UN	8	560	413
50	2	150-300	1/2"-13UNC	8	45	33
		600	9/16"-12UNC	8	65	48
		900	7/8"-9UNC	8	250	184
		1500	7/8"-9UNC	8	250	184
		2500	1-1/8"-8UN	8	560	413
75	3	150-300	5/8"-11UNC	8	90	66
		600	5/8"-11UNC	10	90	66
		900	1-1/8"-8UN	8	560	413
		1500	1-1/8"-8UN	8	560	413
		2500	1-3/8"-8UN	8	1100	811
100	4	150-300	3/4"-10UNC	8	160	118
		600	3/4"-10UNC	10	160	118
		900	1-3/8"-8UN	8	1100	811
		1500	1-3/8"-8UN	8	1100	811
		2500	1-1/2"-8UN	8	1400	1033
150	6	150-300	3/4"-10UNC	8	160	118
		600	7/8"-9UNC	12	250	184
		900	1-1/8"-8UN	12	560	413
		1500	1-3/8"-8UN	12	1100	811
		2500	1-1/2"-8UN	12	1400	1033
200	8	150-300	7/8"-9UNC	12	250	184
		600	1"-8UNC	12	380	280
		900	1-5/8"-8UN	12	1810	1335
		1500	1-5/8"-8UN	12	1810	1335
250	10	150-300	1"-8UNC	16	380	280
		600	1-1/4"-8UN	16	790	583
		900	1-3/8"-8UN	12	1100	811
		1500	1-5/8"-8UN	16	1810	1335
300	12	150-300	1-1/8"-8UN	16	560	413
		600	1-1/4"-8UN	16	790	583
		900	1-3/8"-8UN	20	1100	811
		1500	2-1/4"-8UN	12	4970	3666
		2500	2-3/4"-8UN	12	9225	6804
350	14	150-300	1-1/4"-8UN	16	790	583
		600	1-3/8"-8UN	16	1100	811
		900	1-1/2"-8UN	20	1400	1033
		1500	2-1/2"-8UN	12	6880	5074
400	16	150-300	1-1/4"-8UN	20	790	583
		600	1-3/8"-8UN	20	1100	811
		900	1-5/8"-8UN	20	1810	1335
		1500	2-1/2"-8UN	12	6880	5074

Table 2 Required torques for packing nuts

Packing Type	Stem Size	Rating (ANSI)	Required Torques	
	mm		Min. Nm(lbf ft)	Max. Nm(lbf ft)
Graphite & PTFE packing	Ø12.7	150-300	5(4)	7(5)
		600	6(4)	8(6)
		900	7(5)	10(7)
		1500	9(7)	12(9)
		2500	10(7)	14(10)
	Ø19.05	150-300	11(8)	16(11)
		600	14(10)	19(14)
		900	17(12)	23(17)
		1500	19(14)	27(20)
		2500	22(16)	31(23)
	Ø25.4	150-300	18(13)	25(18)
		600	23(17)	32(24)
		900	27(20)	38(28)
		1500	32(24)	44(32)
		2500	36(27)	51(38)
Ø36	150-300	26(19)	36(27)	
	600	32(24)	45(33)	
	900	39(29)	54(40)	
	1500	45(33)	64(47)	
	2500	52(38)	73(54)	
V-ring packing (PTFE)	Ø12.7	150-300	3(2)	5(4)
		600	4(3)	6(4)
		900	5(4)	7(5)
		1500	6(4)	8(6)
		2500	7(5)	10(7)
	Ø19.05	150-300	8(6)	11(8)
		600	10(7)	14(10)
		900	12(9)	16(12)
		1500	14(10)	19(14)
		2500	16(12)	22(16)
	Ø25.4	150-300	13(10)	18(13)
		600	16(12)	22(16)
		900	19(14)	27(20)
		1500	22(16)	31(23)
		2500	25(18)	35(26)
Ø36	150-300	18(13)	25(18)	
	600	23(17)	32(24)	
	900	27(20)	38(28)	
	1500	32(24)	44(32)	
	2500	36(27)	51(38)	

4.4 Replacing the general trim and body reassembly

NOTE:

AU general trim set consists of the seat, plug and stem, retainer and gaskets (for seat ring and bonnet).

AB/AM general trim set consists of the seat, plug and stem, cage(AM: disk stack), cage guide, seal ring and gaskets (for seat ring and bonnet).

AB/AM high temperature trim set consists of the seat, plug and stem, one-piece cage (AM: disk stack), 3 seal rings and gaskets (for seat ring and bonnet). Please refer to chapter 4.6.

- Make sure the valve is not pressurised.
- Remove the actuator from the valve stem according to the instructions given in the actuator manual and next Section 6.
- Remove the hexagon nuts (18) slightly.
- Remove the hexagon nuts (17).
- Remove the bonnet (8)
- Remove the one unit of stem and plug (5 & 3) with the retainer (10) in case of AU.
 - * Remove the stem and plug (5 & 3) in case of AB & AM.
 - * Remove the cage guide (16), cage (15) and the seal ring (64). Avoid from damaging the seal ring between the cage and cage guide in case of AB & AM.
- Remove the body gasket (65), seat ring(7), seat gasket (63)

CAUTION:

Do not reuse the spiral wound gaskets (63 & 65), this is need to be replace each time the valve is disassembled.

- Remove the hexagon nuts (18), gland flange (9b) and gland (9a)
- Remove the old packing rings (69)

NOTE:

If the valve have excess leakage, the plug and seating surface need lapping and cleaning.

NOTE:

Guide Bushing Removal (AU)

The Retainer Guide Bushing (4) is a press and tag welded fit into the retainer and does not normally necessary replacement. If need, it may be machined out. When machining the bushing out, care must be maintain proper dimensions and tolerances.

NOTE:

'Omega' multi stage Cage Cleaning (AM)

The welded 'Omega' multi stage cage is not available disassembling, make sure the ultrasonic cleaning in the frequency range of 250 ~ 400 kHz and Min. duration 60 min.

- Clean the body gasket surface.
- Insert a new seat gasket (63) and the seat ring (7) into the body.
- Install the valve plug and stem assembly (3 & 5) with the retainer (10) very carefully in case of AU.
- Install the cage (15), seal ring (64), cage guide (16) and plug stem assembly (3, 5, 6) very carefully in case of AB & AM.
- Insert the body gasket (65).

- Mount the bonnet on the body carefully maintaining alignment with the plug and the stem and with the retainer (or cage) in the closed position, so that the arrow on the body and on the bonnet point in the same direction.
- Apply lubricant which is suitable for the process type and temperature to the studs(13), gland studs(14), hexagon nuts(17), nuts(18), stem(5) and thread area properly.
- However, lubricant is not allowed for oxygen service or in any processes with temperature higher than 260°C(550°F).
- Insert the hexagon nuts (17) into stud (13) and slightly fasten the nuts.

CAUTION:

Do not strongly tighten stud nuts at this time.

- Insert the packing ring (69) according to above 4.3

CAUTION:

The all related parts (seat ring, retainer, cage, plug & stem, bonnet) must be properly aligned in the body.

- Tighten hexagon nuts (17) according to the torque table to make proper contact between a plug and a seat ring.

4.5 Pilot balanced plug

Disassembly & Assembly

- After removing the plug stem assembly from the body, mount the plug and stem assembly on the lathe chuck, push the stem to compress the spring inside of the plug.
- Remove the pilot wire (76).
- Remove the pilot bolts (75).

CAUTION:

Make sure to balance when loose the pilot bolts, and be careful the spring tension to bounced off the pilot plug and stem.

- Remove the pilot cover (74).
- Remove the pilot plug (73) and pilot stem (72) from pilot main plug (71).
- Remove the pilot spring (77) carefully.
- Remove the pilot plug (73) and the pilot seat as well as the surface inside of the pilot main plug (71). If there is damage, scratches or grooves, it should be replaced or repaired.
- Insert the cleaned pilot spring (77) into the upper side of main plug.
- Install the pilot plug (73) & stem (72) on the spring (77).
- Install the pilot cover (74) and fasten the pilot bolts (75) keep in balance.
- Install wire (76) for connecting the all pilot bolts to prevent loose on operation.

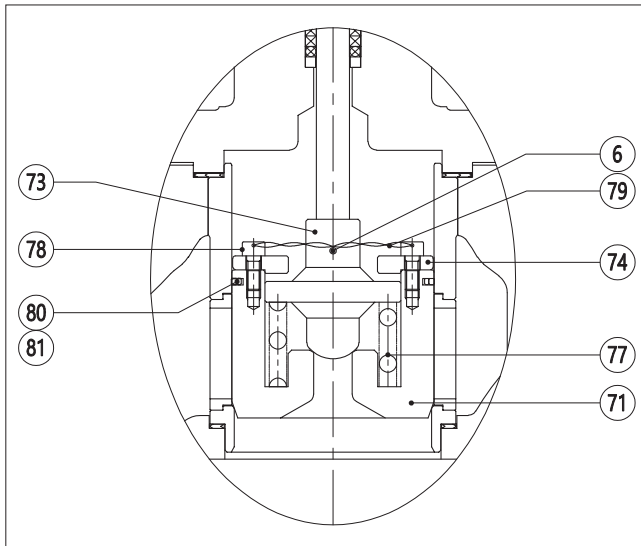

Fig. 9 Pilot balanced trim

4.6 High temperature graphite seal trim

Disassembly

CAUTION:

Disassemble the graphite seal from the cage and plug and stem assembly when the sticking issue or weird noise happens during the valve operation in normal process condition. If not happen, then no need to disassemble the graphite seal.

- After removing the plug stem assembly from the body, mount the cage (15), plug and stem assembly (2) on the lathe chuck horizontally.
- Pull out the plug and stem assembly (2) from the cage (15) by hammering on bottom surface of plug.
- Remove the graphite seal (64) from plug groove one by one.

CAUTION:

Plug and stem assembly will be separated from the cage when 3 sets of graphite seal are out.

- Inspect the cage (15), plug and stem assembly (2) and seat ring (7).
- If there is damage, scratches on grooves, it should be replaced or repaired.

Assembly

- Mount the half of new graphite seal (64) on the chuck.
- Grab the graphite seal (64) by both hands, and push and cut it into the two pieces.
- Repeat to cut the other seal in order to prepare 3 sets of graphite seal.
- Mount the cage (15) on the chuck (or similar instrument) vertically so that the plug and stem assembly (2) can be inserted from up to down.
- Make to align the position of plug and stem assembly (2) in order to insert it to the inside of cage.

- Insert each graphite seal (64) to the plug groove one by one.
- Hammering the stem ends carefully in order to insert the graphite plug seal (64) without the damage.

CAUTION:

When insert each graphite seal to the plug groove, do not mix the cut graphite seal ring each other.

CAUTION:

Make the cut surfaces of graphite seal perfectly fits each other during the inserting to the plug groove.

CAUTION:

Make the graphite plug seal will not be out of groove during the inserting by hammering.

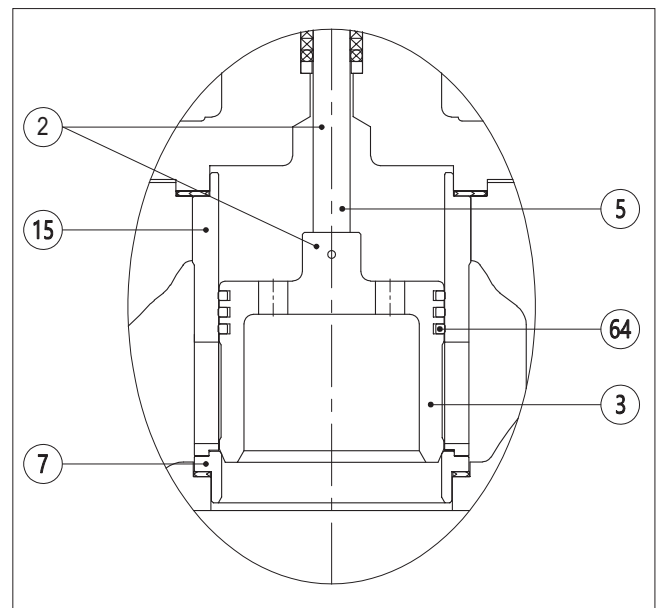

Fig. 10 High temperature graphite seal trim

4.7 High temperature metal seal trim

Disassembly

Before disassembling the valve, fully open the valve using air pressure.

Remove the bonnet and take out the plug and stem assembly (2) (hereafter referred to as the plug set) together with the cage from the body.

NOTE:

For your reference, until before the socket head screws on top of the plug are loosened, the plug set is tightly fitted inside the cage, so when you lift the plug set, the cage will come up together with it.

Place the plug set and the cage on the assembly jig (refer to the jig drawing number in the table below). Loosen the socket head screws (78).

CAUTION:

Once the socket head screws (78) are loosened, the plug set(2) may drop immediately onto the assembly jig due to gravity. Pay special attention to avoid injury to your feet or other body parts.

Remove the internal parts from the cage (15) in the following order: Socket head screws (78), washers (78A), plug cover (86), seal ring (85), plug seal cover (84), plug seal (64), metal seal cover (83), and metal seal (82).

NOTE:

If the plug seals (64) are stuck in the cage and cannot be easily removed, lightly tap it with a rubber mallet to take them out.

Inspect the cage (15), plug set(2), and seat ring (7). If any damage or scratches are found on the contact area where the metal seal (82) is seated inside the cage (15), the cage must be replaced with a new one.

Assembly

Place the cage(5) onto the assembly jig and insert the plug set(2).

NOTE:

The concentricity between the plug set(2) and the cage(15) is critical for seat leakage performance. Always use the assembly jig during reassembly.

Install the metal seal (82) together with the metal seal cover (83). Install one plug seal (64) and plug seal cover (84). Install the second plug seal (64) and the seal ring (85), then install the plug cover (86). Install the socket head screws (78) with washers (78A) and tighten the screws until a 'tick' sound is heard from the washer.

NOTE:

A special anti-loosening washer is used, which produces a 'tick' sound when the screws are properly tightened.

CAUTION:

Do not overtighten the socket head screws.

Finally, remove the assembly jig and install the assembled cage and plug set back into the valve body.

Assembly zig drawing No.

Valve size	Zig drawing no.
2	F119934
3	F119935
4	F119936
6	F119937
8	F119938
10	F119939
12	F119940
14	F119941
16	F119942

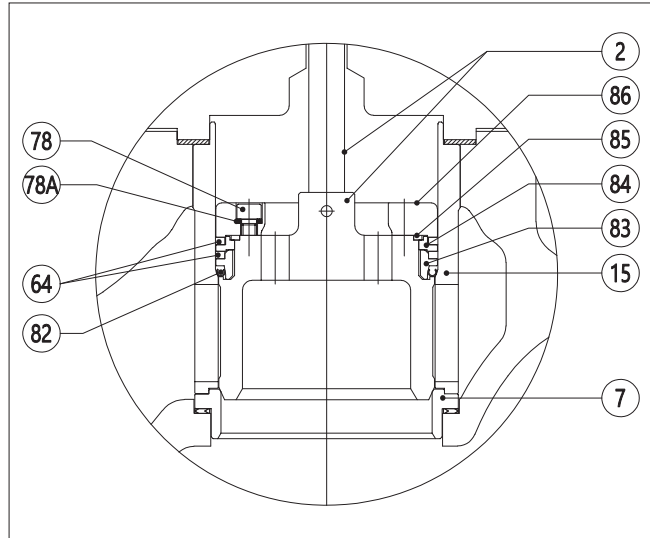

Fig. 11

5. TESTING THE VALVE

CAUTION:

Pressure testing should be carried out using equipment conforming to the correct pressure class!

We recommend that the valve body is pressure-tested after the valve has been assembled.

The pressure test should be carried out in accordance with an applicable standard for the pressure rating. The valve must be in the open position during the test.

Different trim designs

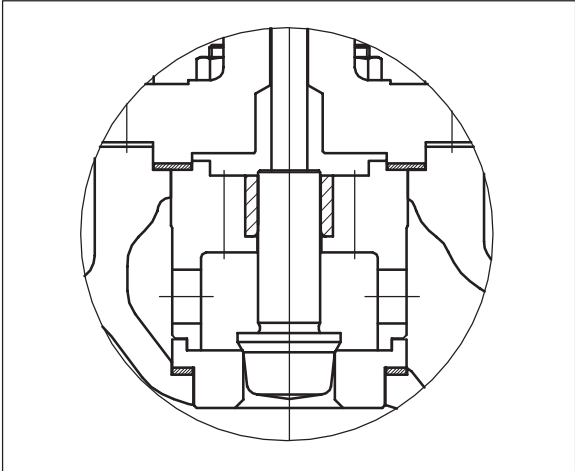

AU, Standard contoured trim

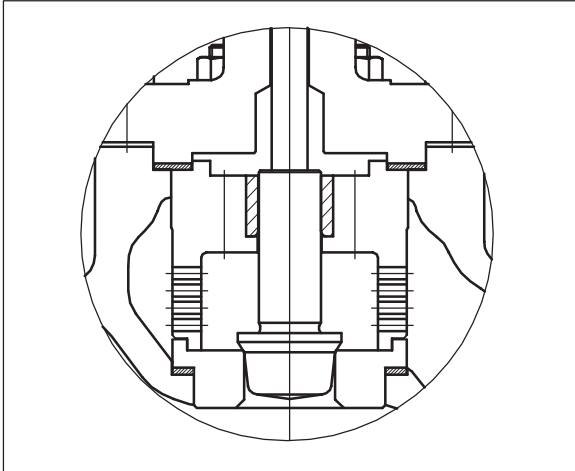

AU, Tendril trim

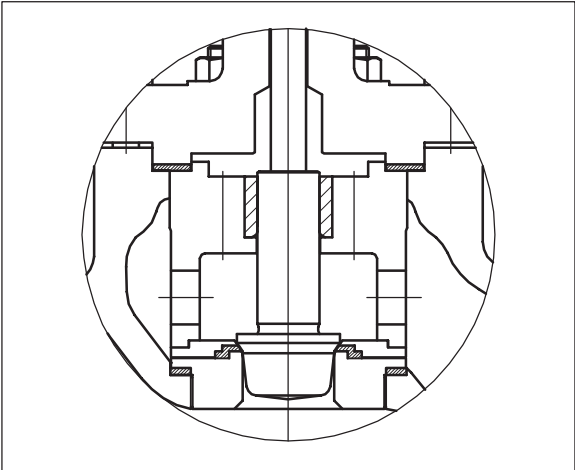

AU, Soft seat trim

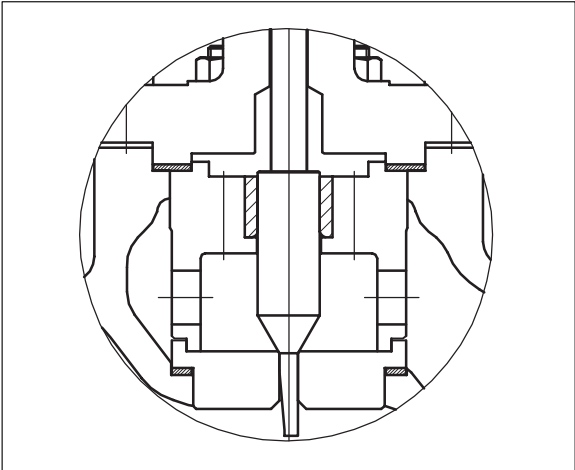

AU, Micro trim

Fig. 12 Different trim designs (AU series)

Trim Design application

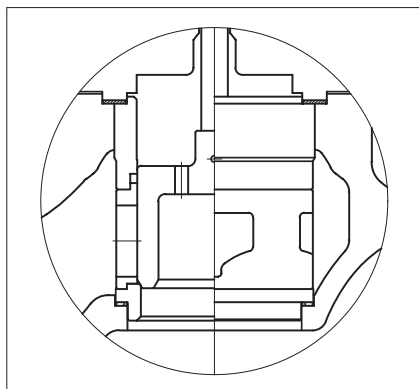

Quick change, standard cage trim

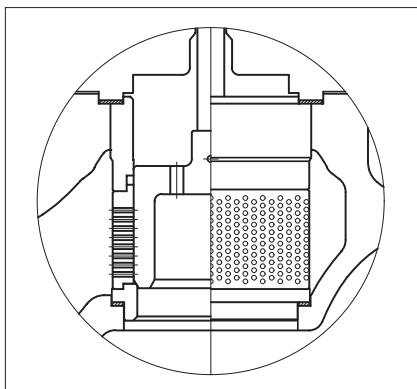

Tendril Multi-hole trim

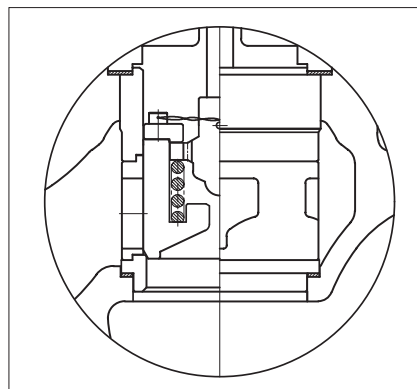

Pilot balanced trim

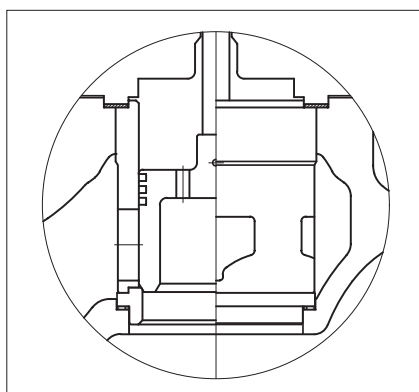

High temperature graphite seal trim

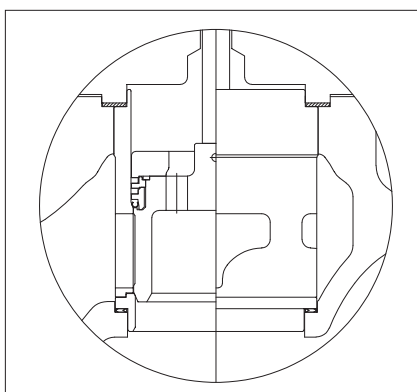

High temperature metal seal trim

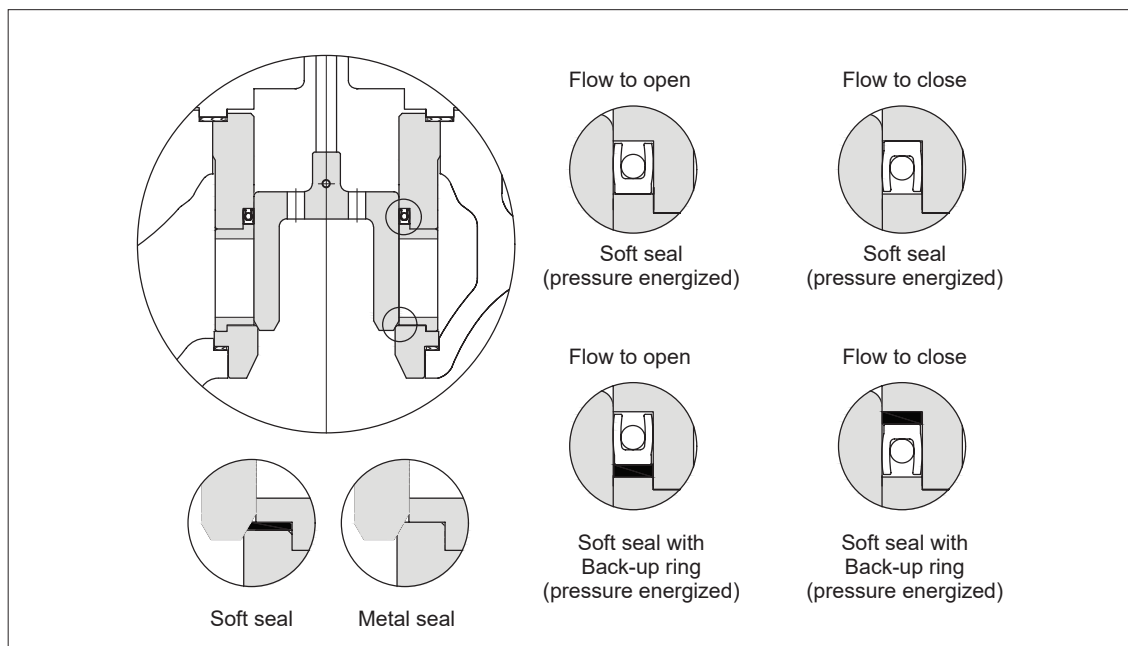

Seal-ring & seat solutions for GB valve trims

Fig. 13 Different trim designs (AB series)

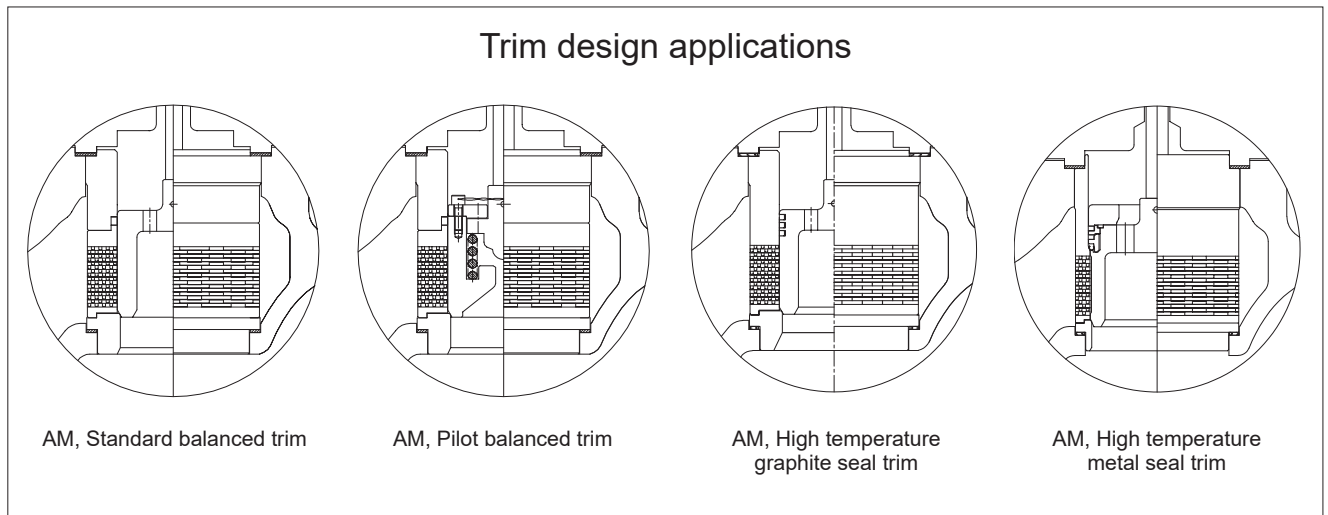

Fig. 14 Different trim designs (AM series)

6. REMOVAL & MOUNTING THE ACTUATOR

Actuator is to be mounted on the valve assembly and is to be reconnected to the valve plug stem according to this manual. There are several types of actuators such as VDR/VDD diaphragm actuator, VBR/VBD spring return cylinder actuator and VBC/VCC spring-less double acting cylinder actuator which requires different clamping. In this manual, VD actuator mounting and removal will be handled. For other types of actuator, please refer to separate IMOs.

CAUTION:

Make sure the valve is not pressurized when removing the actuator.

CAUTION:

Beware of the plug movement!
Do not use air pressure higher than what specified on the identification plate.

NOTE:

Threaded area is required to apply lubricant suitable for process temperature to yoke nut(3**) and clamp(1**).

A. Actuator removal for Reverse <air to open, stem retract> actuator (Fig. 15)

- To prevent personal injury during dismantling, use compressed air to raise the valve plug approximately 20% from the seat ring. Failure to do so may cause clamps to spring out. This is because the actuator stem and valve stem are clamped together under pressure. Therefore, it is necessary to relieve the pressure by lifting the plug before disassembling the clamps.
- Loosen the stem lock nut (5**) and socket head screws (1a**) and hexagon nuts (1b**).
- Remove the clamp (1**).
- Shut off and disconnect air supply line.
- Support actuator with the suitable lifting device.
- Use compressed air to lift the valve stem, and then proceed to remove the yoke nut.
- Remove the actuator from the valve body assembly.

B. Actuator removal for Direct <air to close, stem extend > actuator (Fig. 15)

- Before dismantling the clamps, it is crucial to disconnect the air supply from the actuator to prevent personal injury. Failure to do so may result in the clamps being forcefully ejected, as the actuator stem and valve stem are clamped together under pressure. Therefore, ensure that you remove the pressure by disconnecting the air supply before proceeding with clamp disassembly.
- Loosen stem lock nut (5**) and socket head screws (1a**) and hexagon nuts (1b**).
- Remove the clamp (1**).
- Support actuator with the suitable lifting device.
- Use compressed air to lift the valve stem, and then proceed to remove the yoke nut.
- Remove the actuator from the valve body assembly.

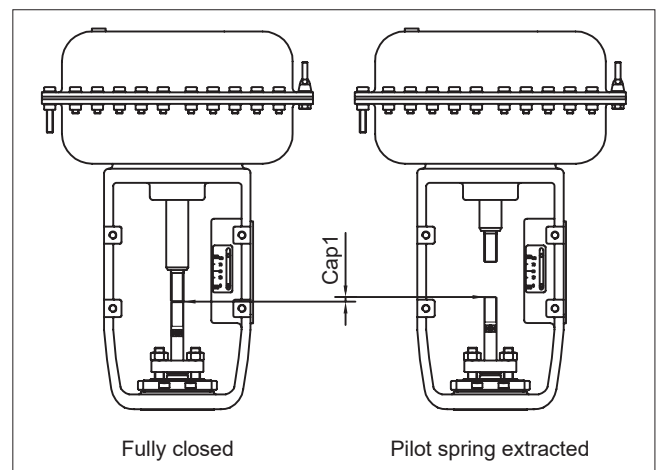

Fig. 15 Measurement of Gap 1

C. Actuator installation

General & high temp balanced trim constructions

- Using the handwheel or pneumatic pressure, lower the valve stem until the plug makes contact with the seat ring. Place a flat object between the valve stem and actuator stem when pushing them down to ensure proper contact between the plug and the seat ring. Ensure that the handwheel indication is in the neutral position before operating the valve pneumatically.

- Employing the handwheel or pneumatic pressure, elevate the actuator stem to its fully retracted position.
- Align the starting point (0) of the ruler with the end of the retracted actuator stem.
- By releasing compressed air, lower the actuator stem by valve stroke and clamp the valve stem and actuator stem together. The actuator stem is to be lifted up by Gap 1 (Gap 1

= Distance between the actuator stem end when fully extended and the actuator stem end when fully retracted - valve stroke). This compression of the actuator springs in this manner can generate shut-off pressure (VDR) and open pressure (VDD) in the event of valve failure.

For more detailed information, please contact your Valmet sales office or service center.

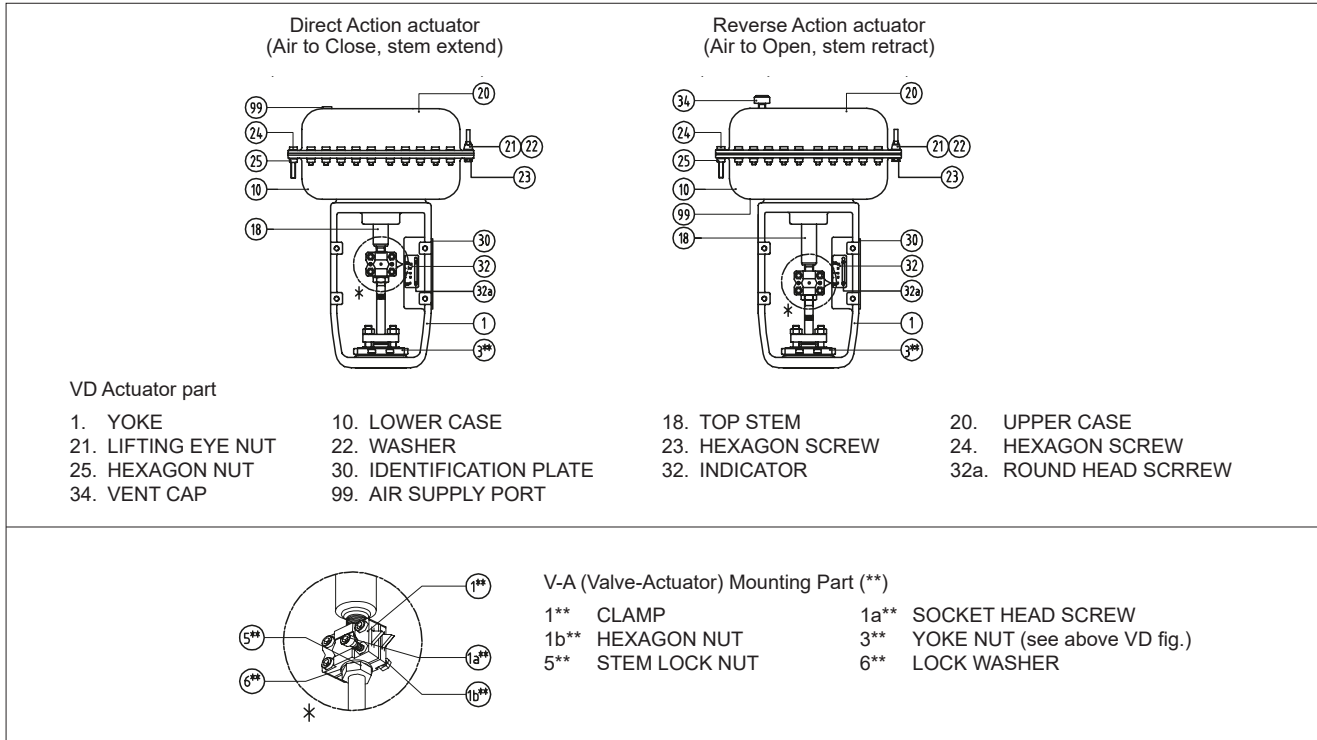

Fig. 16 VD Actuator

Pilot valve construction

- With the handwheel or pneumatically, push the valve stem and plug to be slightly touched with seat ring to make sure if valve is fully closed. And mark the valve stem end location by a line on the yoke or travel indicator.
- And move up the top stem. And mark the valve stem end location by a line on the yoke or travel indicator after valve stem is moved by a spring inside pilot plug.
- Measure the distance between two lines, which is gap 2.
- Stroke the actuator to the fully open.
- Measure the maximum distance between the valve stem and actuator top stem.
- Calculate the gap (measured value – rated travel – gap 2 = gap 3)
- Move down the top stem so that the distance between the valve stem and actuator top stem should be gap 2
- Fit the clamp to align with both stems thread
- Close the valve fully.
- Line up the stroke indicator with the clamp indicator arrow and check actuator for operation.
- Tighten the socket head screws after adjusted the rated stroke.

D. Installing VB, VC piston actuator

- VBD and VBR actuators are spring piston actuators for single acting. Please refer to its IMOs for further information.
- VBC and VCC actuators are double acting piston actuators without spring. Please refer to its IMOs for further information.

CAUTION:

Avoid to turn the valve plug and stem when plug is on seat ring to prevent the seating line from being damaged.

7. TOOLS

Removal of the actuator

- L- wrench set (mm)
- hex socket wrench set
- chisel and hammer (10 pound)
- +,- drivers)
- Special tool for packing insertion
- Special tool for packing removal

8. ORDERING SPARE PARTS

NOTE:

Always use original spare parts to make sure that the valve functions as intended.

When ordering spare parts, always include the following information:

- type code, sales order number, serial number
- number of the parts list, part number, name of the part and quantity required

This information can be found from the identification plate or documents.

9. EXPLODED VIEW AND PARTS LIST

AU

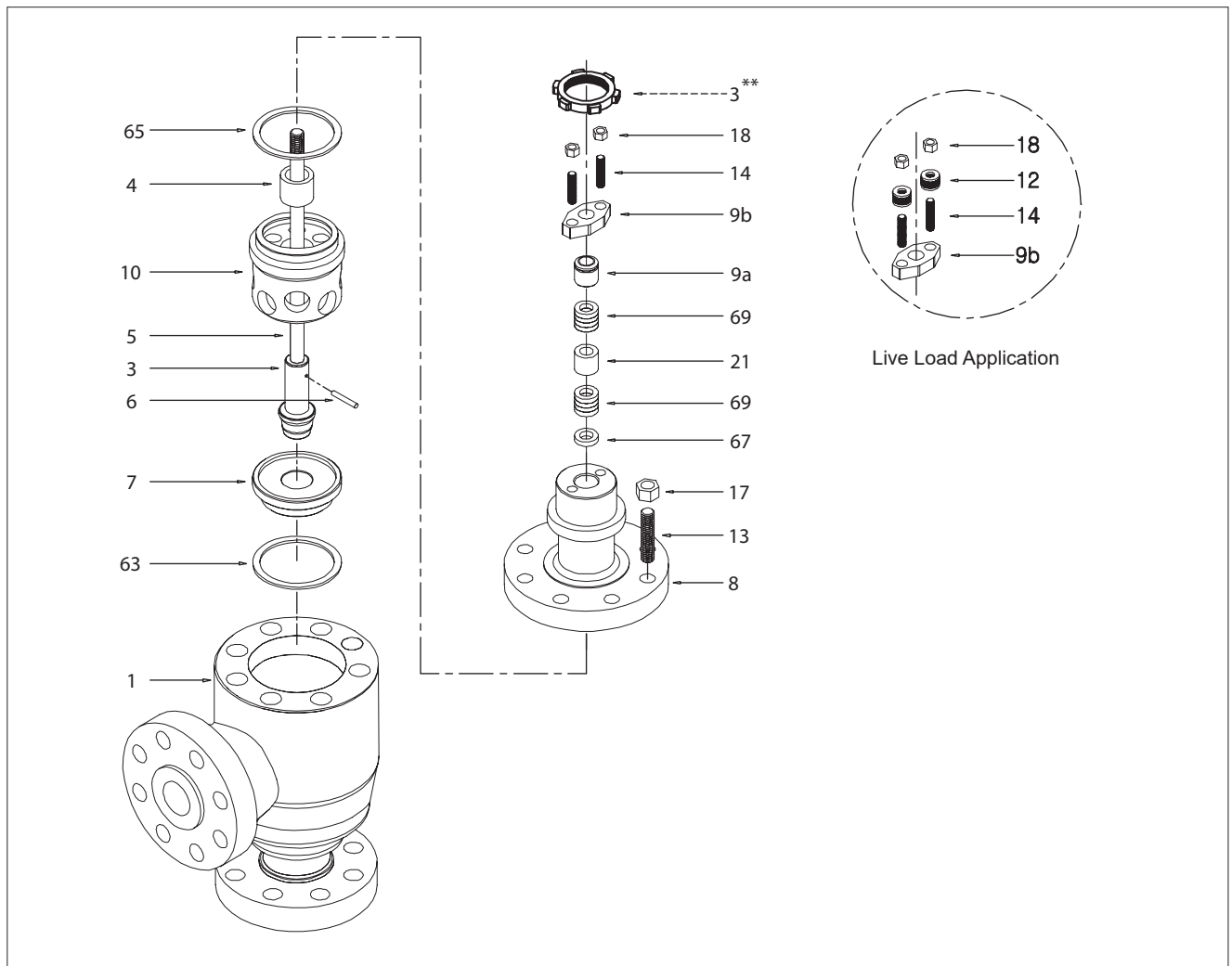

Item	Description	Recommended spare part
1	BODY	
2*	PLUG SET	
	3* PLUG	
	5* STEM	
	6* PLUG PIN	
3**	YOKE NUT	
4	GUIDE BUSHING	
7	SEAT RING	
8	BONNET	
9a	GLAND	
9b	GLAND FLANGE	
10	RETAINER	
12	DISK SPRING ASS'Y	
13	STUD	
14	STUD	
17	HEXAGON NUT	
18	HEXAGON NUT	
21	LANTERN RING	
63	SEAT GASKET	X
65	BODY GASKET	X
65A	BODY GASKET	X
67	PACKING SPACER	
69	PACKING RING	X

*) Delivered as a set

**) V-A Mounting Parts

**) Part no. 65A applicable only for 20" and 24"

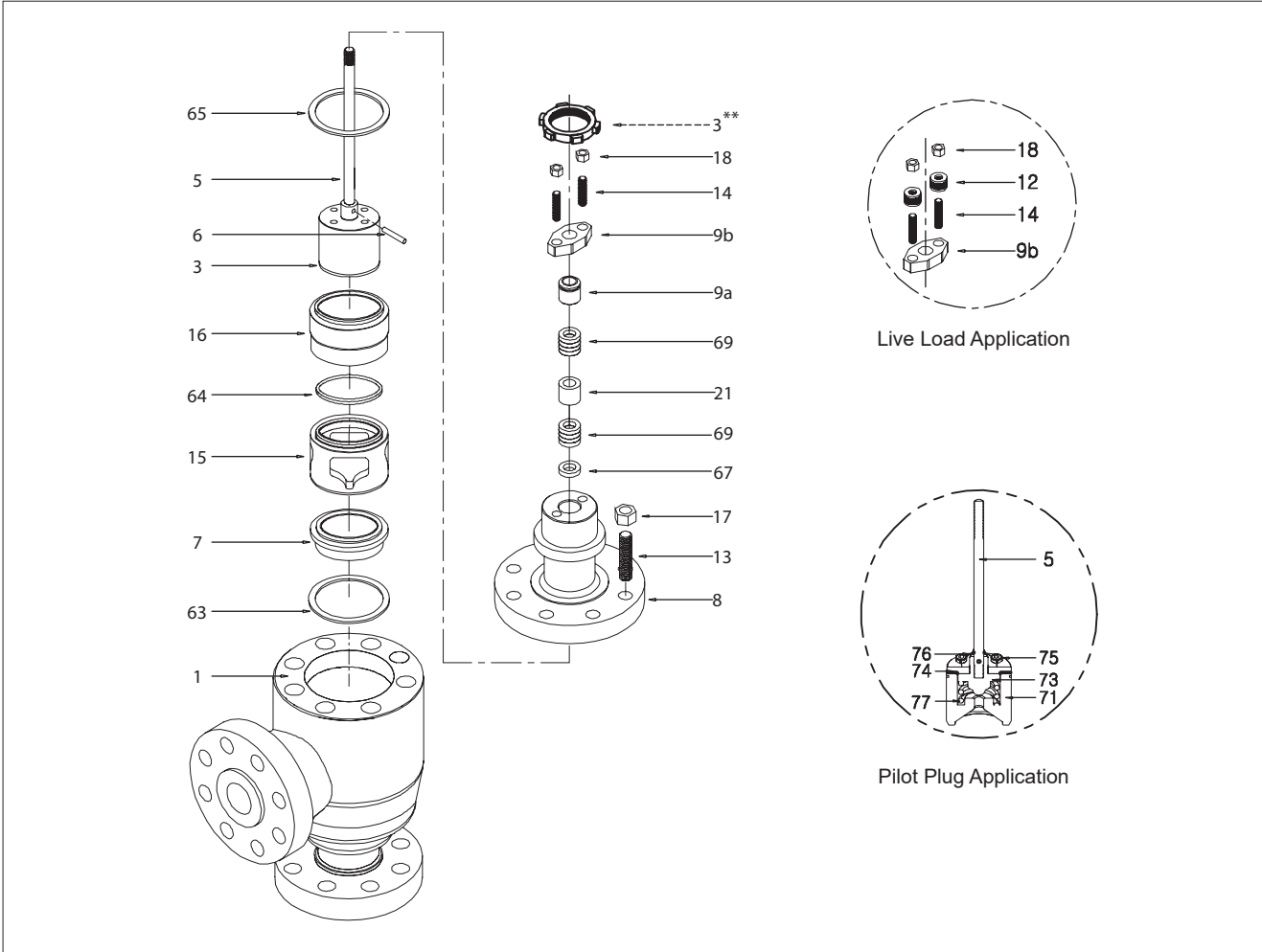

Item	Description	Recommended spare part
1	BODY	
2*	PLUG SET	
	3* PLUG	
	5* STEM	
	6* PLUG PIN	
3**	YOKE NUT	
7	SEAT RING	
8	BONNET	
9a	GLAND	
9b	GLAND FLANGE	
12	DISK SPRING ASS'Y	
13	STUD	
14	STUD	
15	CAGE	
16	CAGE GUIDE	
17	HEXAGON NUT	
18	HEXAGON NUT	
21	LANTERN RING	
63	SEAT GASKET	X
64	SEAL RING	X
65	BODY GASKET	X
65A	BODY GASKET	X
67	PACKING SPACER	
69	PACKING RING	X
71	PILOT MAIN PLUG	
73	PILOT PLUG	
74	PILOT COVER	
75	PILOT BOLT	
76	PILOT WIRE	
77	PILOT SPRING	

*) Delivered as a set
 **) V-A Mounting Parts
 ***) Part no. 65A applicable only for 20" and 24"

AM

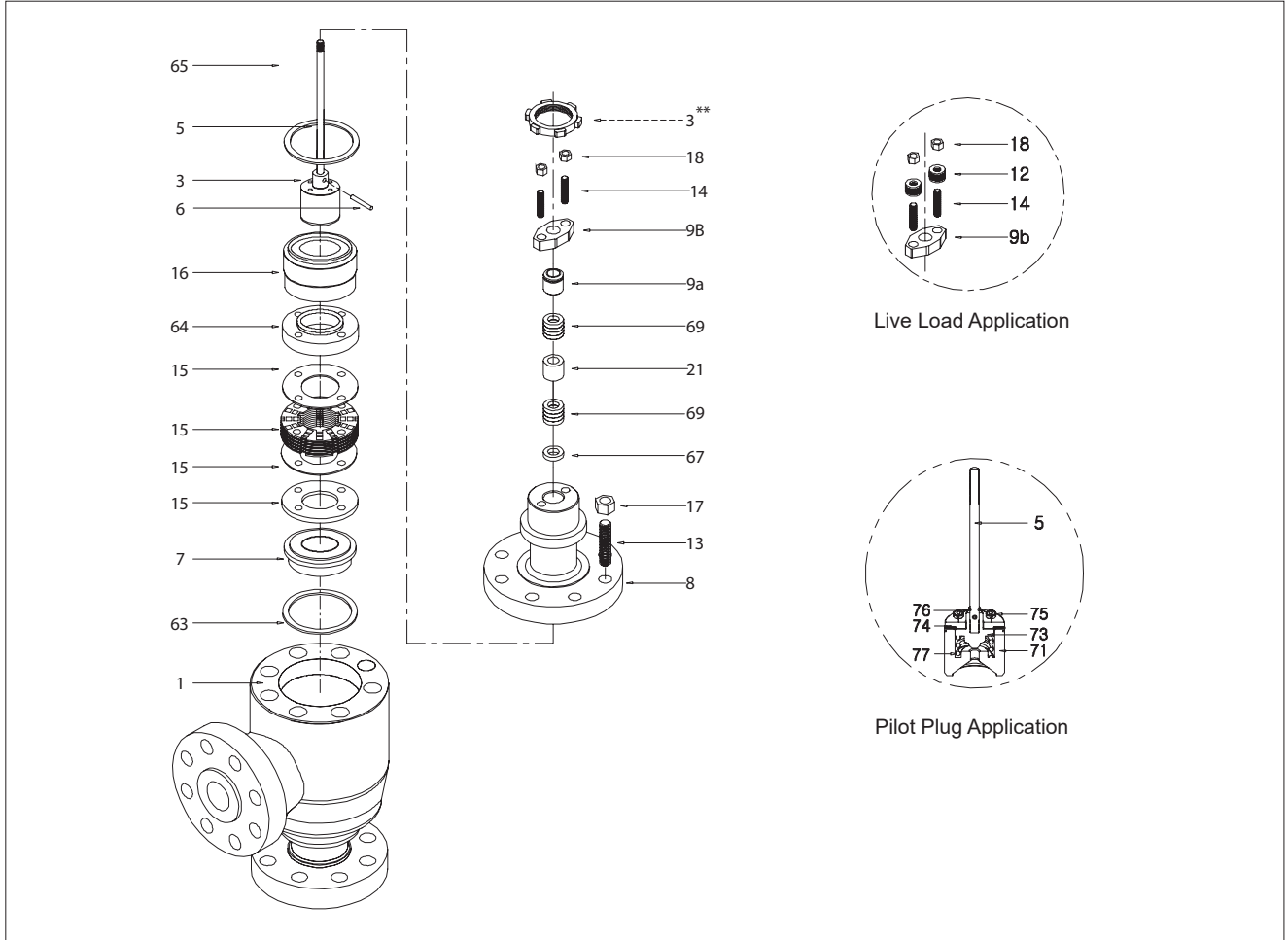

Item	Description	Recommended spare part
1	BODY	
2*	PLUG SET	
	3* PLUG	
	5* STEM	
	6* PLUG PIN	
3**	YOKE NUT	
7	SEAT RING	
8	BONNET	
9a	GLAND	
9b	GLAND FLANGE	
12	DISK SPRING ASS'Y	
13	STUD	
14	STUD	
16	CAGE GUIDE	
17	HEXAGON NUT	
18	HEXAGON NUT	
21	LANTERN RING	
25	DISK STACK	
63	SEAT GASKET	X
64	SEAL RING	X
65	BODY GASKET	X
65A	BODY GASKET	X
67	PACKING SPACER	
69	PACKING RING	X
71	PILOT MAIN PLUG	
73	PILOT PLUG	
74	PILOT COVER	
75	PILOT BOLT	
76	PILOT WIRE	
77	PILOT SPRING	

*) Delivered as a set

**) V-A Mounting Parts

***) Part no. 65A applicable only for 20" and 24"

10. DIMENSIONS AND WEIGHTS

10.1 Valve AU, AB, AM

A series, valve dimensions and weights

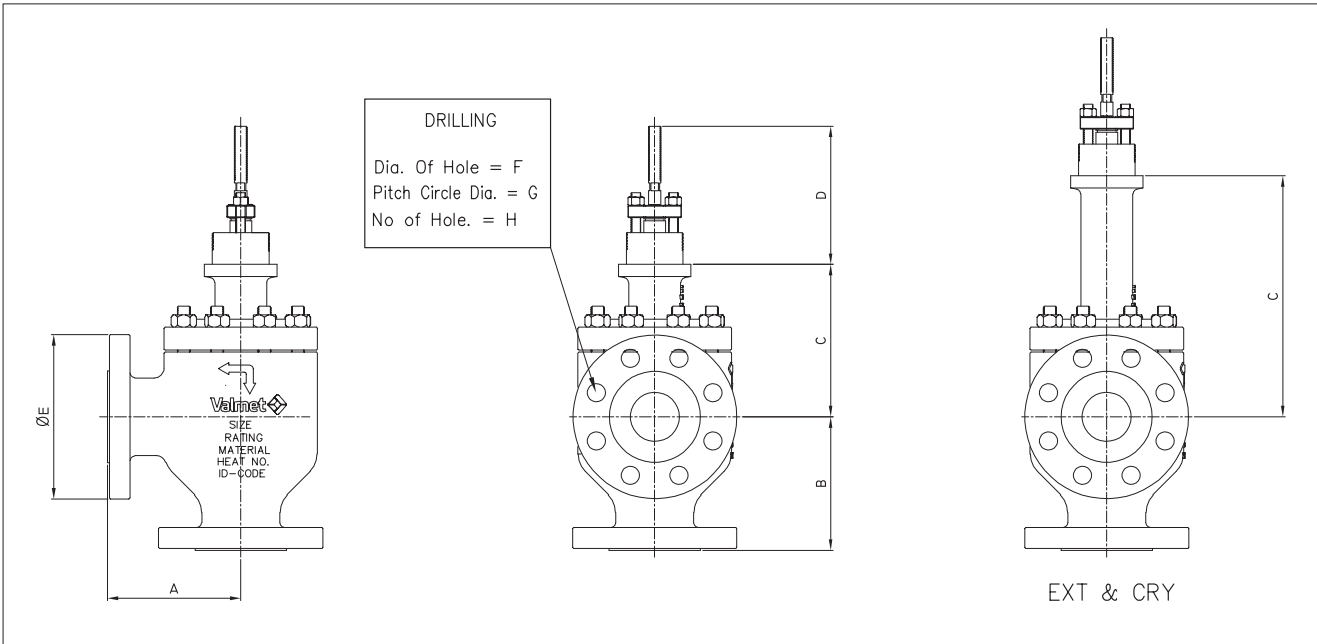

150 #/ 300 #/ 600

Dimension (mm)	A			B			C			D	E			F			G			H			Weight (kg) (Approximate)		
	150#	300#	600#	150#	300#	600#	STD	EXT	CRYO	COMMON	150#	300#	600#	150#	300#	600#	150#	300#	600#	150#	300#	600#	150#	300#	600#
25	92	99	105	92	99	105	142	250	400	110	110	125	125	15.9	19.1	19.1	79.4	88.9	88.9	4	4	4	29	29	29
40	111	117	125	111	117	125	161	269	419	110	125	155	155	15.9	22.2	22.2	98.4	114.3	114.3	4	4	4	42	42	45
50	127	133	143	127	133	143	178	333	458	110	150	165	165	19.1	19.1	19.1	120.7	127	127	4	8	8	61	61	61
80	149	159	168	149	159	168	222	395	545	115	190	210	210	19.1	22.2	22.2	152.4	168.3	168.3	4	8	8	104	104	109
100	176	184	197	176	184	197	248	402	552	140	230	255	275	19.1	22.2	25.4	190.5	200	215.9	8	8	8	164	164	181
150	226	236	254	226	236	254	340	467	642	150	280	320	355	22.2	22.2	28.6	241.3	269.9	292.1	8	12	12	236	236	273
200	272	284	305	272	284	305	451	557	732	150	345	380	420	22.2	25.4	31.8	298.5	330.2	349.2	8	12	12	282	329	436
250	337	354	376	337	354	376	488	670	870	150	405	445	510	25.4	28.6	34.9	362	387.4	431.8	12	16	16	553	553	784
300	369	388	410	369	388	410	543	716	916	150	485	520	560	25.4	31.8	34.9	431.8	450.8	489	12	16	20	880	880	1139
350	445	464	486	445	464	486	616	846	1046	210	535	585	605	28.6	31.8	38.1	476.3	514.4	527	12	20	20	1238	1238	1572
400	508	529	554	508	529	554	692	909	1109	220	595	650	685	28.6	34.9	41.3	539.8	571.5	603.2	16	20	20	1622	1622	2262

Dimension (inch)	A			B			C			D	E			F			G			H			Weight (lb) (Approximate)		
	150#	300#	600#	150#	300#	600#	STD	EXT	CRYO	COMMON	150#	300#	600#	150#	300#	600#	150#	300#	600#	150#	300#	600#	150#	300#	600#
1"	7.2	7.8	8.3	2.2	2.5	2.5	5.6	9.8	15.7	4.3	4.3	4.9	4.9	0.625	0.75	0.75	3.1	3.5	3.5	4	4	4	68	68	68
1.5"	8.7	9.3	9.9	2.6	3.1	3.1	6.3	10.6	16.5	4.3	4.9	6.1	6.1	0.625	0.875	0.875	3.9	4.5	4.5	4	4	4	79	79	97
2"	5.0	5.2	5.6	5.0	5.2	5.6	7.0	13.1	18.0	4.3	5.9	6.5	6.5	0.75	0.75	0.75	4.8	5.0	5.0	4	8	8	134	134	134
3"	5.9	6.3	6.6	5.9	6.3	6.6	8.7	15.6	21.5	4.5	7.5	8.3	8.3	0.75	0.875	0.875	6.0	6.6	6.6	4	8	8	229	229	240
4"	6.9	7.2	7.8	6.9	7.2	7.8	9.8	15.8	21.7	5.5	9.1	10.0	10.8	0.75	0.875	1.00	7.5	7.9	8.5	8	8	8	362	362	399
6"	8.9	9.3	10.0	8.9	9.3	10.0	13.4	18.4	25.3	5.9	11.0	12.6	14.0	0.875	0.875	1.125	9.5	10.6	11.5	8	12	12	520	520	602
8"	10.7	11.2	12.0	10.7	11.2	12.0	17.8	21.9	28.8	5.9	13.6	15.0	16.5	0.875	1.00	1.25	11.8	13.0	13.7	8	12	12	622	725	961
10"	13.3	13.9	14.8	13.3	13.9	14.8	19.2	26.4	34.3	5.9	15.9	17.5	20.1	1.00	1.125	1.375	14.3	15.3	17.0	12	16	16	1219	1219	1728
12"	14.5	15.3	16.1	14.5	15.3	16.1	21.4	28.2	36.1	5.9	19.1	20.5	22.0	1.00	1.25	1.375	17.0	17.7	19.3	12	16	20	1940	1940	2511
14"	17.5	18.3	19.1	17.5	18.3	19.1	24.3	33.3	41.2	8.3	21.1	23.0	23.8	1.125	1.25	1.50	18.8	20.3	20.7	12	20	20	2729	2729	3466
16"	20.0	20.8	21.8	20.0	20.8	21.8	27.2	35.8	43.7	8.7	23.4	25.6	27.0	1.125	1.375	1.625	21.3	22.5	23.7	16	20	20	3576	3576	4987

900 #/ 1500 #

Dimension (mm)	A		B		C		D	E		F		G		H		Weight (kg) (Approximate)	
	900#	1500#	900#	1500#	STD	EXT	COMMON	900#	1500#	900#	1500#	900#	1500#	900#	1500#	900#	1500#
25	146	146	146	146	229	330	110	150	150	25.4	25.4	101.6	101.6	4	4	73	73
40	167	167	167	167	278	380	110	180	180	28.6	28.6	123.8	123.8	4	4	90	90
50	188	188	188	188	300	400	110	215	215	25.4	25.4	165.1	165.1	8	8	132	132
80	221	230	221	230	330	430	115	240	265	25.4	31.8	190.5	203.2	8	8	210	226
100	256	265	256	265	350	450	140	290	310	31.8	34.9	235	241.3	8	8	314	394
150	357	384	357	384	393	500	150	380	395	31.8	38.1	317.5	317.5	12	12	502	726
200	457	486	457	486	480	600	150	470	485	38.1	44.5	393.7	393.7	12	12	1144	1278
250	496	534	496	534	518	650	150	545	585	38.1	50.8	469.9	482.6	16	12	1109	2040
300	565	610	565	610	680	800	150	610	675	38.1	54	533.4	571.5	20	16	1892	3182
350	629	629	629	629	770	920	210	640	750	41.3	60.3	558.8	635	20	16	1964	3648
400	711	711	711	711	850	1050	220	705	825	44.5	66.7	616	704.8	20	16	2765	5297

Dimension (inch)	A		B		C		D	E		F		G		H		Weight (lbf) (Approximate)	
	900#	1500#	900#	1500#	STD	EXT	COMMON	900#	1500#	900#	1500#	900#	1500#	900#	1500#	900#	1500#
1"	11.5	11.5	3.2	3.2	9.3	13.0	4.3	5.9	5.9	1.0	1.0	4.0	4.0	4	4	165	165
1.5"	13.1	13.1	3.5	3.5	9.8	15.0	4.3	7.1	7.1	1.125	1.125	4.9	4.9	4	4	216	216
2"	7.4	7.4	7.4	7.4	11.8	15.7	4.3	8.5	8.5	0.875	0.875	6.5	6.5	8	8	291	291
3"	8.7	9.1	8.7	9.1	13.0	16.9	4.5	9.4	10.4	0.875	0.875	7.5	8.0	8	8	463	498
4"	10.1	10.4	10.1	10.4	13.8	17.7	5.5	11.4	12.2	1.25	1.375	9.3	9.5	8	8	692	869
6"	14.1	15.1	14.1	15.1	15.5	19.7	5.9	15.0	15.6	1.25	1.5	12.5	12.5	12	12	1107	1601
8"	18.0	19.1	18.0	19.1	18.9	23.6	5.9	18.5	19.1	1.5	1.75	15.5	15.5	12	12	2522	2818
10"	19.5	21.0	19.5	21.0	20.4	25.6	5.9	21.5	23.0	1.5	2.0	18.5	19.0	16	12	2445	4497
12"	22.2	24.0	22.2	24.0	26.8	31.5	5.9	24.0	26.6	1.5	2.125	21.0	22.5	20	16	4171	7015
14"	24.8	24.8	24.8	24.8	30.3	36.2	8.3	25.2	29.5	1.625	2.375	22.0	25.0	20	16	4330	8042
16"	28.0	28.0	28.0	28.0	33.5	41.3	8.7	27.8	32.5	1.75	2.625	24.3	27.7	20	16	6096	11678

* Larger sizes and ASME class 2500 are available, please contact Valmet.

10.2 Actuator VDD/VDR

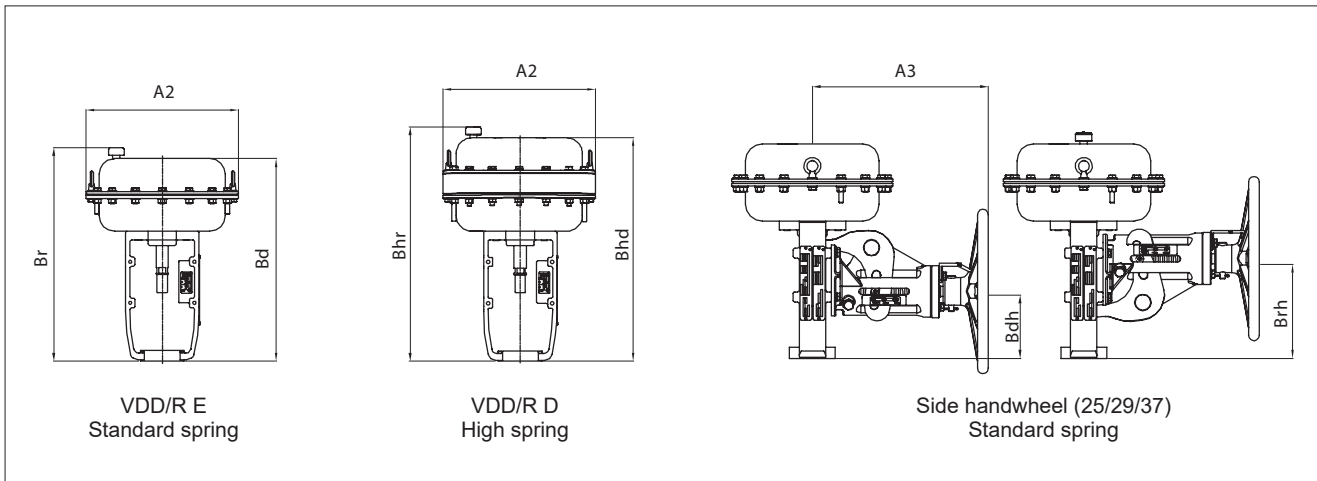

Dimension (mm)	Size (mm)	Without handwheel				With handwheel				
		A2	Bd / Bhhd	Br / Bhr	Weight (kg)	A2	A3	Bdh	Brh	Weight (kg)
VD_25 E		255	348	373	12	255	312	110	170	23
VD_25 D		255	373	395	17	255	312	110	170	28
VD_29 E		295	391	416	18	295	312	122	182	29
VD_29 D		295	431	453	26	295	312	122	182	32
VD_37 E		375	464	489	28	375	352	131	211	43
VD_37 D		375	514	535	46					

Dimension (inch)	Size (inch)	Without handwheel				With handwheel				
		A2	Bd / Bhhd	Br / Bhr	Weight (lbs)	A2	A3	Bdh	Brh	Weight (lbs)
VD_25 E		10	14	15	26	10	12	4	7	51
VD_25 D		10	15	16	37	10	12	4	7	62
VD_29 E		12	15	16	40	12	12	5	7	64
VD_29 D		12	17	18	57	12	12	5	7	82
VD_37 E		15	18	19	62	15	14	5	8	95
VD_37 D		15	20	21	101					

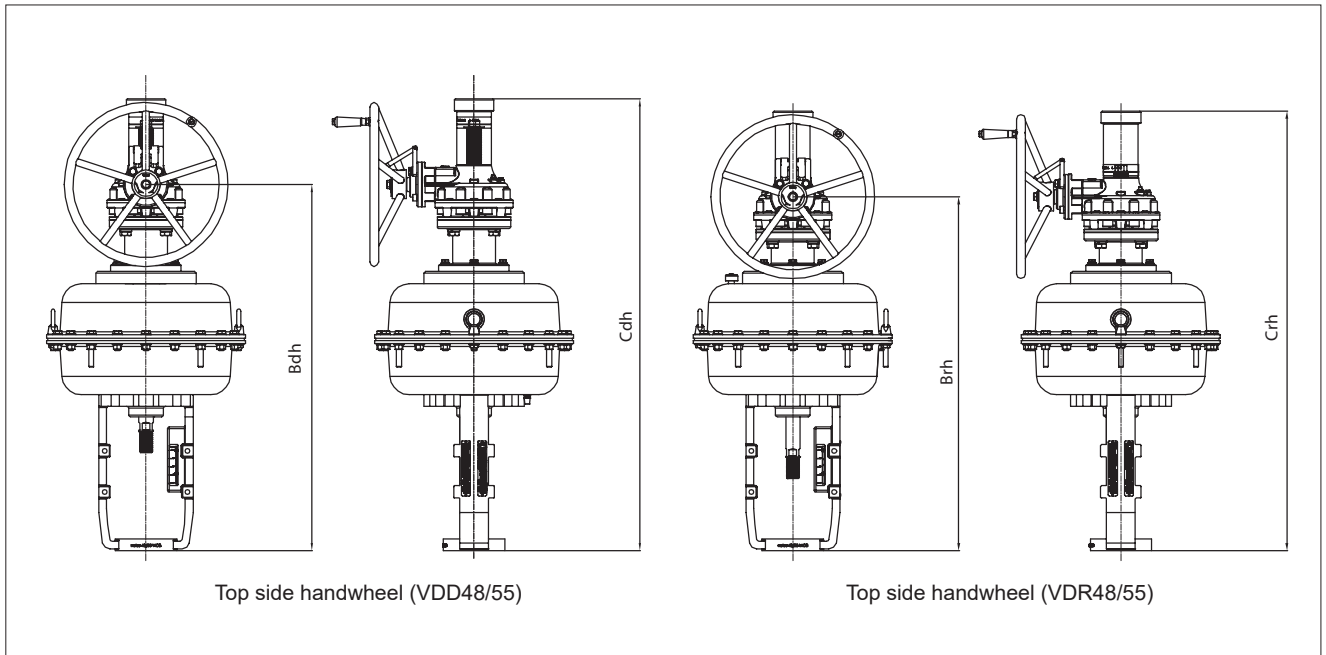

Dimension (mm)	Size (mm)	Without handwheel				With handwheel				
		A2	Bd / Bhd	Br / Bhr	Weight (kg)	Bdh	Brh	Cdh	Crh	Weight (kg)
	VD_48 E	486	652	677	86	896	865	1102	1072	112
	VD_48 D	486	702	724	118	946	915	1152	1122	144
	VD_55 E	566	695	720	112	940	910	1145	1115	145
	VD_55 D	566	745	767	152					

Dimension (inch)	Size (inch)	Without handwheel				With handwheel				
		A2	Bd / Bhd	Br / Bhr	Weight (lbs)	Bdh	Brh	Cdh	Crh	Weight (lbs)
	VD_48 E	19	26	27	190	35	34	43	42	247
	VD_48 D	19	28	29	260	37	36	45	44	317
	VD_55 E	22	27	28	247	37	36	45	44	320
	VD_55 D	22	29	30	335					

NOTE

1. "E" refers to Spring range 0.8~2.6
2. "D" refers to Spring range 1.5~3.4
3. "Br / Bhr" refers to reverse acting actuator, VDR E / D
4. "Bd / Bhd" refers to direct acting actuator, VDD E / D
5. "Cdh / Crh" Top side handwheel actuator, VD_48/55

10.3 Actuator VBD/R

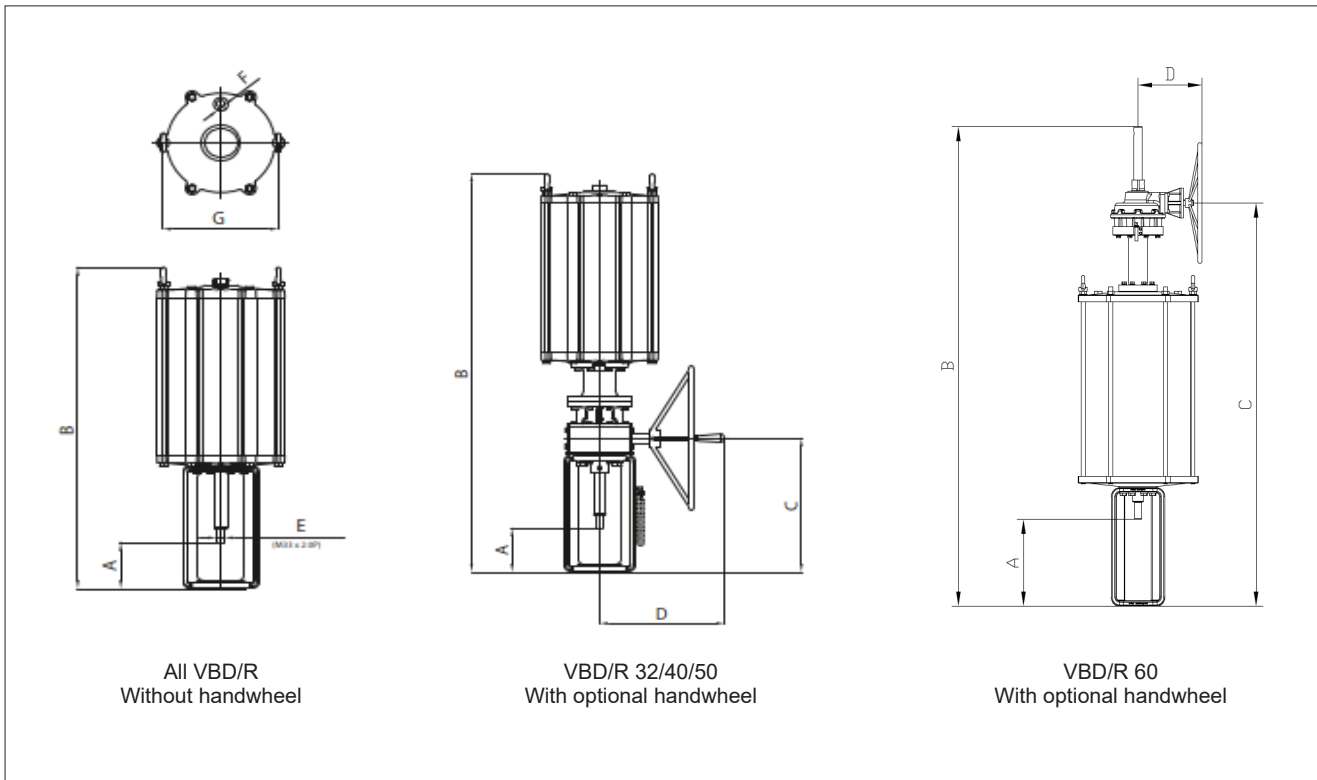

Dimension (mm)	Stroke Range	Without handwheel					With handwheel				
		A	B	F	G	Weight (kg)	A	B	C	D	Weight (kg)
VBD/R32	60...120	278 / 158	1069	3/4" NPT	392	154	280 / 160	1393	471	417	205
VBD/R40	60...180	365 / 185	1449	3/4" NPT	314	314	358 / 178	1798	619	427	392
VBD/R50	60...180	365 / 185	1531	1" NPT	503	503	358 / 178	1879	619	427	446
VBD/R60	60...280	222	1913	1" NPT	724	826	222	2774	2332	333	986

Dimension (inch)	Stroke Range	Without handwheel					With handwheel				
		A	B	F	G	Weight (lbs)	A	B	C	D	Weight (lbs)
VBD/R32	1.97...4.72	10.9 / 6.2	42,0	3/4" NPT	15.4	340	11 / 6,3	54,8	18,5	16,4	452
VBD/R40	2.36...7.09	14.4 / 7.3	57.157,0	3/4" NPT	19.6	692	14 / 7	70,8	16,8	16,8	864
VBD/R50	2.36...7.09	14.4 / 7.3	60.460,3	1" NPT	24	1109	14 / 7	74,0	16,8	16,8	1226
VBD/R60	2.36...11.02	8,7	75,3	1" NPT	28,5	1821	8,7	109,2	13,1	13,1	2173

10.4 Actuator VBC

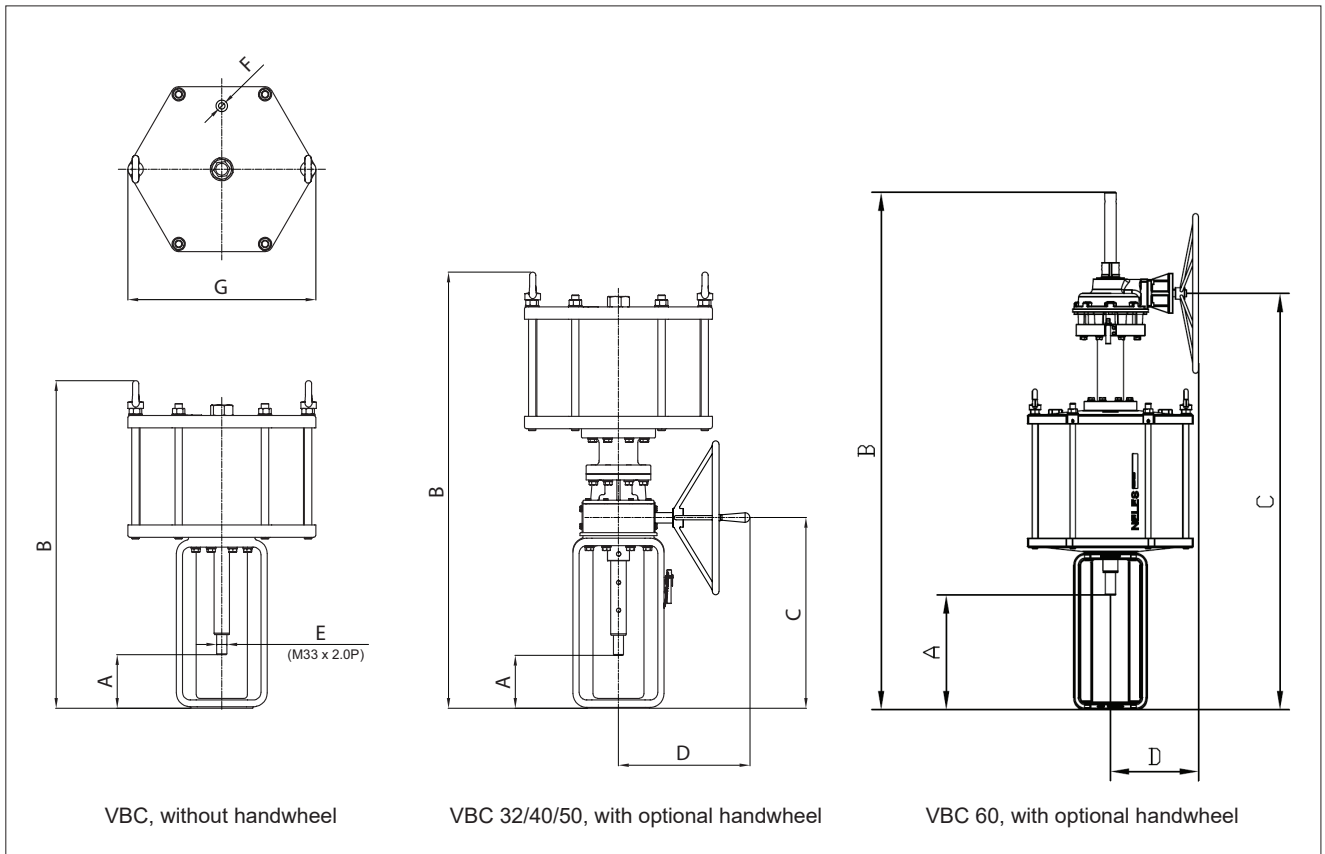

Dimension (mm) / Size	Stroke Range	Without handwheel					With handwheel				
		A	B	F	G	Weight (kg)	A	B	C	D	Weight (kg)
VBC32	50,60,70,80,120	153	769	3/4" NPT	392	96	158	1093	471	417	147
VBC40	60,70,80,120,140,160,180	185	1054	3/4" NPT	499	190	185	1403	619	427	263
VBC50	60,70,80,120,140,160,180	184	1066	1" NPT	610	297	179	1415	619	427	371
VBC60_V	140,160,180, 200, 280	222	1404	1" NPT	724	507	222	2265	1823	333	660

Dimension (mm) / Size	Stroke Range	Without handwheel					With handwheel				
		A	B	F	G	Weight (lbs)	A	B	C	D	Weight (lbs)
VBC32	50,60,70,80,120	6	30.3	3/4" NPT	15.4	212	6.2	43	18.5	16.4	324
VBC40	60,70,80,120,140,160,180	7.3	41.5	3/4" NPT	19.6	419	7.3	55.2	24.4	16.8	580
VBC50	60,70,80,120,140,160,180	7.2	42	1" NPT	24	655	7	55.7	24.4	16.8	818
VBC60_V	140,160,180, 200, 280	8.7	55.3	1" NPT	25.8	1117.7	179	1415	619	427	1455

10.5 Actuator VBC with volume chamber

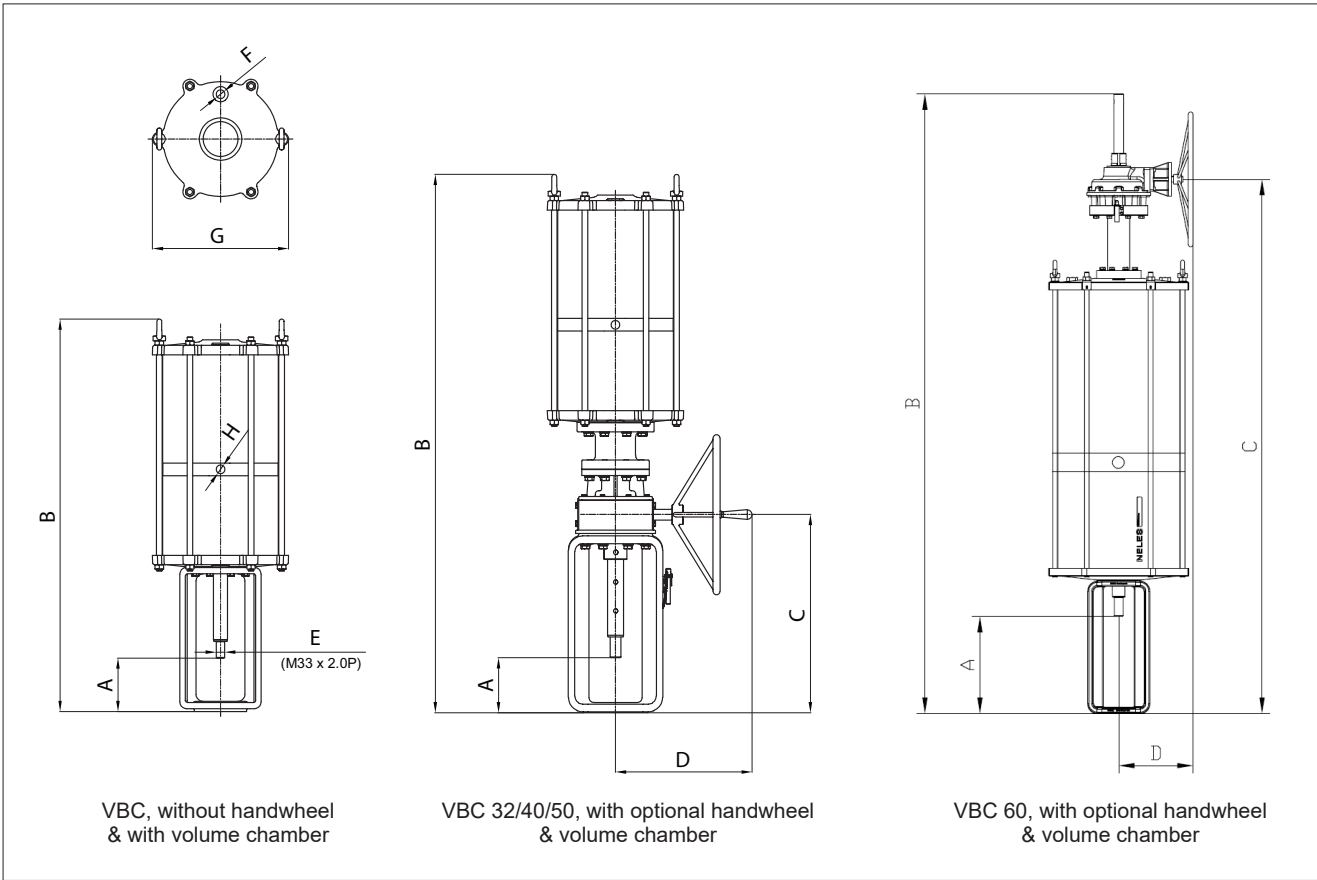

Dimension (mm) / Size	Stroke Range	Without handwheel						With handwheel				
		A	B	F	G	H	Weight (kg)	A	B	C	D	Weight (kg)
VBC32_V	50,60,70,80,120	153	1116	3/4" NPT	392	3/4" NPT	129	158	1440	471	417	180
VBC40_V	60,70,80,120,140,160,180	185	1550	3/4" NPT	499	3/4" NPT	255	185	1899	619	427	329
VBC50_V	60,70,80,120,140,160,180	184	1570	1" NPT	610	1" NPT	415	179	1919	619	427	490
VBC60_V	140,160,180, 200, 280	222	1903	1" NPT	724	1" NPT	787	222	3045	2603	333	950

Dimension (mm) / Size	Stroke Range	Without handwheel						With handwheel				
		A	B	F	G	H	Weight (lbs)	A	B	C	D	Weight (lbs)
VBC32_V	50,60,70,80,120	6	43,9	3/4" NPT	15,4	3/4" NPT	284	6,2	56,7	18,5	16,4	397
VBC40_V	60,70,80,120,140,160,180	7,3	61	3/4" NPT	19,7	3/4" NPT	562	7,3	74,8	24,4	16,8	725
VBC50_V	60,70,80,120,140,160,180	7,2	61,8	1" NPT	24	1" NPT	915	7	75,6	24,4	16,8	1080
VBC60_V	140,160,180, 200, 280	8,7	74,9	1" NPT	28,5	1" NPT	1735	8,7	119,9	102,5	13,1	2094

10.6 Actuator VCC without handwheel

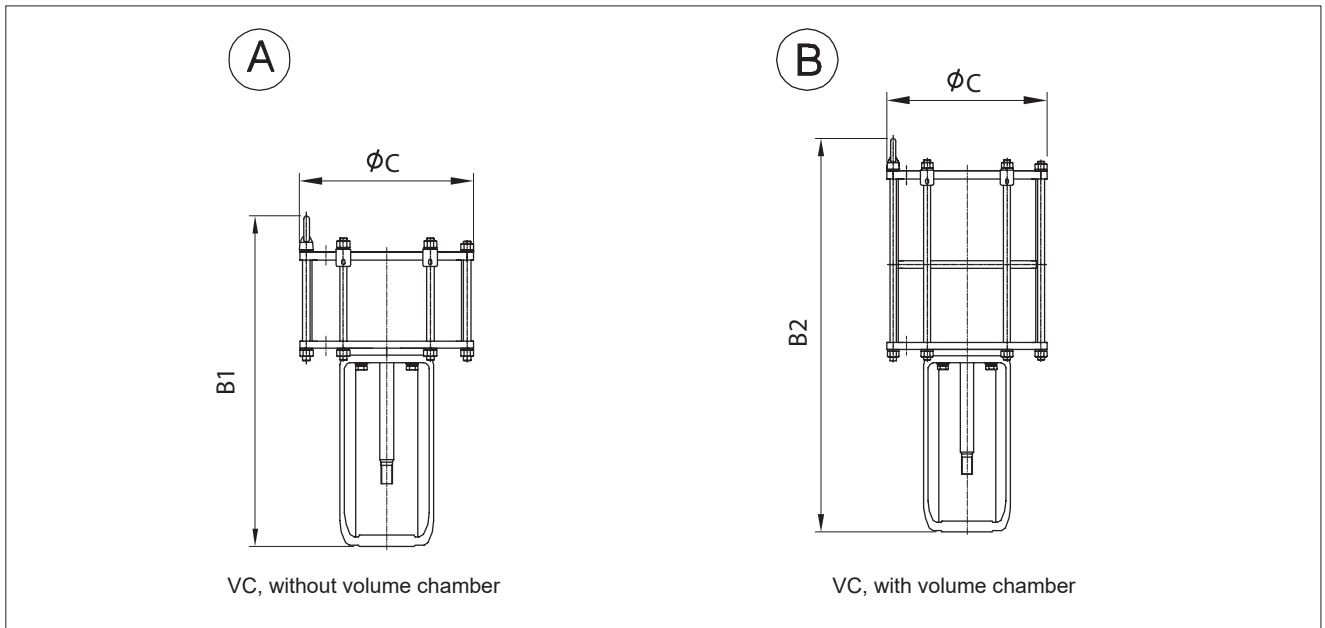

VC actuator without handwheel

Stroke (mm)	# 30			# 40			# 50		
	C	370		C	460		C	560	
	B1	Weight (kg)		B1	Weight (kg)		B1	Weight (kg)	
	B2	A	B	B2	A	B	B2	A	B
40	640	92	115	810	120	148	810	186	234
	760			935			935		
50	650	94	118	820	123	152	820	189	237
	790			965			965		
60	660	97	121	830	126	155	830	192	242
	820			995			995		
70	670	100	124	840	128	159	840	195	246
	850			1025			1025		
80	680	103	127	850	131	162	850	198	251
	880			1055			1055		
90	690	106	130	860	134	166	860	201	256
	910			1085			1085		
100	700	108	133	870	137	173	870	203	261
	940			1115			1115		
120	720	114	139	890	142	177	890	209	270
	1000			1175			1175		
140				910	148	184	910	215	279
				1235			1235		
180				950	159	198	950	227	298
				1355			1355		

Stroke (mm)	# 60			# 70			# 80		
	C	660		C	710		C	820	
	B1	Weight (kg)		B1	Weight (kg)		B1	Weight (kg)	
	B2	A	B	B2	A	B	B2	A	B
100	954	255	344	955	322	438	954	378	519
	1199			1203			1207		
120	974	262	355	975	330	450	974	386	531
	1259			1263			1267		
140	994	269	365	995	338	461	994	394	543
	1319			1323			1327		
180	1034	283	386	1035	354	484	1034	410	567
	1439			1443			1447		
240	1094	303	417	1095	377	518	1094	435	604
	1619			1623			1627		
280							1134	451	628
							1747		

VC actuator without handwheel

Stroke (mm)	# 30			# 40			# 50		
	C	15		C	18		C	22	
	B1	Weight (lbs)		B1	Weight (lbs)		B1	Weight (lbs)	
	B2	A	B	B2	A	B	B2	A	B
40	25	203	254	32	265	326	32	410	516
	30			37			37		
50	26	207	260	32	271	335	32	417	522
	31			38			38		
60	26	214	267	33	278	342	33	423	534
	32			39			39		
70	26	220	273	33	282	351	33	430	542
	33			40			40		
80	27	227	280	33	289	357	33	437	553
	35			42			42		
90	27	234	287	34	295	366	34	443	564
	36			43			43		
100	28	238	293	34	302	381	34	448	575
	37			44			44		
120	28	251	306	35	313	390	35	461	595
	39			46			46		
140				36	326	406	36	474	615
				49			49		
180				37	351	437	37	500	657
				53			53		

Stroke (mm)	# 60			# 70			# 80		
	C	26		C	28		C	32	
	B1	Weight (lbs)		B1	Weight (lbs)		B1	Weight (lbs)	
	B2	A	B	B2	A	B	B2	A	B
100	38	562	758	38	710	966	37	833	1144
	47			47			48		
120	38	578	783	38	728	992	38	851	1171
	50			50			50		
140	39	593	805	39	745	1016	39	869	1197
	52			52			52		
180	41	624	851	41	780	1067	41	904	1250
	57			57			57		
240	43	668	919	43	831	1142	43	959	1332
	64			64			64		
280							45	994	1385
							69		

10.7 Actuator VCC with handwheel

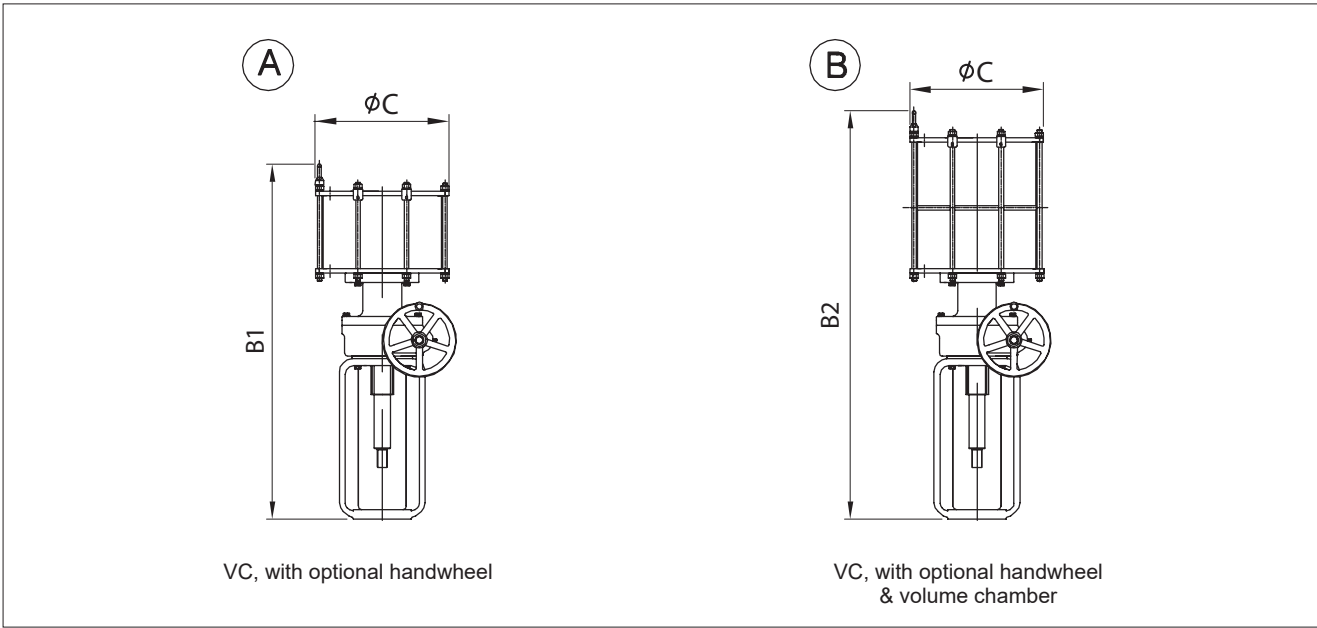

VC actuator with handwheel

Stroke (mm)	#30			#40			#50		
	C	370		C	460		C	560	
	B1	Weight (kg)		B1	Weight (kg)		B1	Weight (kg)	
	B2	A	B	B2	A	B	B2	A	B
40	930	134	157	1095	180	208	1095	246	294
	1055			1220					
50	940	137	160	1105	183	212	1105	249	299
	1085			1250					
60	950	139	163	1115	186	215	1115	252	303
	1115			1280					
70	960	142	167	1125	188	219	1125	255	308
	1145			1310					
80	970	144	170	1135	191	222	1135	258	313
	1175			1340					
90	980	147	173	1145	194	226	1145	261	318
	1205			1370					
100	990	150	176	1155	197	230	1155	263	322
	1235			1400					
120	1010	155	183	1175	202	237	1175	269	332
	1295			1460					
140				1195	208	244	1195	275	341
				1520			1520		
180				1235	219	258	1235	287	360
				1640			1640		

Stroke (mm)	#60			#70			#80		
	C	660		C	710		C	820	
	B1	Weight (kg)		B1	Weight (kg)		B1	Weight (kg)	
	B2	A	B	B2	A	B	B2	A	B
100	1239	315	404	1240	368	502	1289	438	579
	1484			1488					
120	1259	322	415	1260	376	514	1309	446	591
	1544			1548					
140	1279	329	425	1280	384	525	1329	454	603
	1604			1608					
180	1319	343	446	1320	400	548	1369	470	627
	1724			1728					
240	1379	363	477	1380	423	582	1429	495	664
	1904			1908					
280							1469	511	688
							2082		

VC actuator with handwheel

Stroke (mm)	#30			#40			#50		
	C	15		C	18		C	22	
	B1	Weight (lbs)		B1	Weight (lbs)		B1	Weight (lbs)	
	B2	A	B	B2	A	B	B2	A	B
40	37	295	346	43	397	459	43	542	648
	42			48					
50	37	302	353	44	403	467	44	549	659
	43			49					
60	37	306	359	44	410	474	44	556	668
	44			50					
70	38	313	368	44	414	483	44	562	679
	45			52					
80	38	317	375	45	421	489	45	569	690
	46			53					
90	39	324	381	45	428	498	45	575	701
	47			54					
100	39	331	388	45	434	507	45	580	710
	49			55					
120	40	342	403	46	445	522	46	593	732
	51			57					
140				47	459	538	47	606	752
				60			60		
180				49	483	569	49	633	794
				65			65		

Stroke (mm)	#60			#70			#80		
	C	26		C	28		C	32	
	B1	Weight (lbs)		B1	Weight (lbs)		B1	Weight (lbs)	
	B2	A	B	B2	A	B	B2	A	B
100	49	694	891	49	811	1107	51	966	1276
	58			58					
120	50	710	915	50	829	1133	52	983	1303
	61			61					
140	50	725	937	50	847	1157	52	1001	1329
	63			63					
180	52	756	983	52	882	1208	54	1036	1382
	68			68					
240	54	800	1052	54	933	1283	56	1091	1464
	75			75					
280							58	1127	1517
							82		

11. EU DECLARATION OF CONFORMITY FOR ATEX APPROVED VALVES



EU DECLARATION OF CONFORMITY



Manufacturer:
Valmet Flow Control Korea Co., Ltd.
Chungju, Chungbuk-do 27466
Korea

for ATEX approved valves

EU Authorised Representative: Valmet Flow Control Oy, Vanha Porvoontie 229, 01380
Vantaa, Finland. Contact details: [+358 10 417 5000](tel:+358104175000)

This declaration of conformity is issued under the sole responsibility of the manufacturer.

Product:	Neles Globe valves		
Type:	A-series (AB, AM, AU)		
ATEX group and category:		II 2 GD, II 3 GD	
Ex GAS:	Ex h IIC 85°C...Tmax Gb		
Ex DUST:	Ex h IIIC T85°C...T(Tmax) Db		
Tmax= valve max. temperature in name plate			

Manufacturer's certificates:

Standard / Directive	Notified Body and NoBo number	Certificate No.
ISO 9001:2015	LRQA (Certification body)	10531829
PED 2014/68/EU Module H	DNV Business Assurance Italy S.r.l. 0496	142306-2013-CE-FIN-ACCREDIA
ATEX 2014/34/EU Annex IV	DNV Product Assurance AS Norway 2460	Presafe 18 ATEX 91983Q Issue 6

ATEX 2014/34/EU Annex VIII technical files are archived by Notified Body number 0537

The object of the declaration described above is in conformity with the relevant Union harmonisation legislation:

PED 2014/68/EU	Valve
ATEX 2014/34/EU	Non-electrical equipment

Main components:

Valve: The valve is suitable for service up to PED Cat III Valve design standard: ASME B16.34

Installation, Maintenance and Operating instructions manual (IMO) must be followed before installation in order to ensure proper and safe mounting and usage of equipment.

The product above is manufactured in compliance with the applicable European directives and technical specifications/standards (EN10204). The product is in conformity with the customer order.

Instrumentation and accessories having equal protection concept, level and performance specification with the original can be presumed to be in conformity with this Declaration of Conformity.

Protection from e.g. static electricity caused by the process or connected equipment must be considered by the user (EN 60079-14 § 6). EN 60079-19 applies for modifications.

Non-electrical equipment is according EN 80079-37:2016 and EN 80079-36:2016. The actual surface temperature of non-electrical equipment is depended on the process and ambient conditions (EN 80079-36:2016 § 6.2.5 and 6.2.7). The protection from high or low temperature must be considered by the end user before put into service.

The product does not possess any residual risk according to hazard analysis conducted under the applicable directives providing that the procedures stated by the IMO are followed and the product is used under conditions mentioned in the technical specifications.

Documents with digital and/or e-signature conveyed by Valmet Flow Control conform to the Regulation (EU) No 910/2014 as well as the national code on e-signatures. In order to secure the integrity of the document, the authenticity of the sender, and indisputableness of the dispatch the identification is covered by individual ID codes, passwords, and by regularly changing passwords. The authorization to sign documents is based on organizational position and/or is task related. The impartial third party in the company bestows the access right with predefined authorities to particular databases.

Chungju 10.9.2024

Juha Virolainen, Global Quality Director

12. TYPE CODE

Angle Unbalanced, Top Guided Type, Series AU																					
1.	2.	3.	4.	5.	6.	7.	8.	9.	10.	11.	12.	13.	14.	15.	16.	17.	18.	19.	20.	21.	22.
AU	01	C	W	A	J2	B	P1	X	BC	S1	R1	X	S	G	X	S	G	X	A	L	FC

VALVE CONSTRUCTIONS

1.	VALVE SERIES		
AU	Angle Unbalanced, Top guided type		

2.	BODY SIZE		
0H	0.5" / DN 15	3Q	0.75" / DN 20
01	1" / DN 25	1H	1.5" / DN 40
02	2" / DN 50	03	3" / DN 80
04	4" / DN 100	06	6" / DN 150
YY	Special		

3.	PRESSURE RATING		
C	ASME Class 150	D	ASME Class 300
F	ASME Class 600	G	ASME Class 900
H	ASME Class 1500	I	ASME Class 2500
J	EN PN 10	K	EN PN 16
L	EN PN 25	M	EN PN 40
N	EN PN 63	P	EN PN 100
B	EN PN 160	E	EN PN 250
Y	EN PN 320		

4.	END CONNECTION		
W	Flanged RF, ASME B16.5		
Z	Ring joint flange, ASME B16.5		
V	Socket welding, ASME B16.11		
Q	Butt welding, ASME B16.25		
Y	Special		

5.	BONNET CONSTRUCTION	
	Bonnet type	Actuator connection
A	General	Applicable for VD_25/29/37
B	General	Applicable for VD_48/55
C	General	Applicable for VC_30, VB_32
D	General	Applicable for VC/VB_40/50/60/70
E	Extension	Applicable for VD_25/29/37
F	Extension	Applicable for VD_48/55
G	Extension	Applicable for VC_30, VB_32
H	Extension	Applicable for VC/VB_40/50/60/70
P	Cryogenic	Applicable for VD_25/29/37
Q	Cryogenic	Applicable for VD_48/55
R	Cryogenic	Applicable for VC_30, VB_32
S	Cryogenic	Applicable for VC/VB_40/50/60/70
Y	Special	Special

6.	BODY MATERIAL	
J2	A216 gr. WCB	
S6	A351 gr. CF8M	
J4	A217 gr. WC6	
CG	A217 gr. WC9	
S1	A351 gr. CF3M	
YY	Special	

- Bonnet material is equivalent to Body material.

7.	MODEL CODE	
B	Model B	

- * ASME valve face to face length according to ISA 75.08.
- * The body, bonnet, trim materials are subject to change as equivalent depending on detail design.
- * See 'Neles Globe Typecode Instruction' for further options and explanations.

TRIM CONSTRUCTIONS

8.	PLUG MATERIAL	
	Material	Description
P1	410 SS	Standard for carbon steel body
T6	316 SS	Standard for stainless steel body
VM	Alloy 6	Use for small Cv and Micro plug
P2	420J2	General for Cr-Mo valve
S1	316L SS	
YY	Special	Special materials

9.	PLUG APPLICATION	
X	Not applicable	
A	Cobalt based alloy	
Y	Special	

10.	STEM MATERIAL	
	Material	Description
BC	630 SS	General for carbon steel valve
TC	316 SS	General for stainless steel valve
FC	316L SS	
VX	XM-19	General for Cr-Mo valve

11.	SEAT TYPE	
S1	Single metal seat	
T1	Single soft seat	
YY	Special	

12.	SEAT / RETAINER MATERIAL		
	Seat	Retainer	Guide bushing
R1	410 SS	CB7Cu-1 / 630 SS	AISI 440C
T6	316 SS	CF8M / 316 SS	AISI 316 + Alloy 6
V6	Alloy 6	CF8M / 316 SS	AISI 316 + Alloy 6
P2	420J2	CA40/420J2	AISI 440C
R2	420J2 SS	CB7Cu-1 / 630 SS	AISI 440C
R3	316L SS	316L SS	AISI 316 + Alloy 6
YY	Special	Special	Special

- AISI 410 is general for carbon steel valve.
- AISI 316 is general for stainless steel valve.

13.	SEAT APPLICATION	
X	Not applicable	
A	Cobalt based alloy	
P	Insert PTFE	
Q	Insert PTFE + Cobalt based alloy	
Y	Special	

OTHERS

14.	PACKING / BELLOWS TYPE
S	General packing
E	Low emission, Live loaded
C	Bellows Seal (316L SS, Formed)
Y	Special

18.	STUD / NUT MATERIAL
G	A193 gr. B7M / A194 gr. 2HM
D	A193 gr. B8M/ A 194 gr. 8M
H	A193 gr. B16 / A194 gr. 7
E	A453 gr. 660/ A453 gr. 660

15.	PACKING MATERIAL
G	PTFE + Carbon fiber
F	Graphite
T	PTFE V-Ring
C	PTFE + Carbon fiber (ATEX)
H	Hi-Graphite
Y	Special

19.	OPTIONS
X	Not applicable
E	Anti-erosion
H	Alloy 6 coating on plug & plug guide for High temp. (top-guided valve only)
L	Lub. & Isol. valve
W	Water seal
Y	Special

16.	SEALS RING MATERIAL
X	Not applicable

17.	GASKET MATERIAL
S	S/W gasket type, 316L SS + Graphite
H	S/W gasket type, 316L SS + Graphite for high temp.
L	S/W gasket type, 316L SS + Hi-Graphite
Y	Special

- * Face to face length according to ISA 75.08
- * The body, bonnet, trim materials are subject to change as equivalent depending on detail design.
- * See 'Neles Globe Typecode Instruction' for further options and explanations.

TRIM TYPE & RATED Cv

20. Sign	TRIM TYPE	21. Sign	TRIM CHARACTERISTIC	22. Sign	Description	RATED Cv													
						Body size and Stroke													
						1/2" Str.	3/4" Str.	1" Str.	1-1/2" Str.	2" Str.	3" Str.	4" Str.	6" Str.						
A	High temp. balanced plug	L	Linear	FC	Full capacity	7 (20)	9 (20)	13.5 (20)	28 (20)	49 (20)	100 (40)	190 (40)	295 (60)						
					E	Equal %	1A 1-Step reduction	4 (20)	5.5 (20)	8.5 (20)	16 (20)	28 (20)	70 (40)	120 (40)	165 (60)				
							2A 2-Step reduction	2.3 (20)	3 (20)	5.4 (20)	10.5 (20)	17 (20)	42 (40)	72 (40)	85 (60)				
							3A 3-Step reduction	1.5 (20)	2 (20)	3.1 (20)	6 (20)	10 (20)	25 (40)	42 (40)	50 (60)				
							4A 4-Step reduction	0.8 (20)	1.2 (20)	2 (20)	4 (20)								
							5A 5-Step reduction	0.5 (20)	0.7 (20)	1.2 (20)	2.2 (20)								
							6A 6-Step reduction	0.3 (20)	0.4 (20)	0.8 (20)	1.2 (20)								
					T	Tendril 1 stage /				Full capacity	7 (20)	9 (20)	13.5 (20)	28 (20)	49 (20)	100 (40)	1.9 (40)		
										1T 1-Step reduction	4 (20)	5.5 (20)	8.5 (20)	16 (20)	28 (20)	70 (40)	120 (40)		
										2T 2-Step reduction	2.3 (20)	3 (20)	5.4 (20)	10.5 (20)	17 (20)	42 (40)	72 (40)		
										3T 3-Step reduction	1.5 (20)	2 (20)	3.1 (20)	6 (20)	10 (20)	25 (40)	42 (40)		
										4T 4-Step reduction	0.8 (20)	1.2 (20)	2 (20)	4 (20)					
										5T 5-Step reduction	0.5 (20)	0.7 (20)	1.2 (20)	2.2 (20)					
C	Micro plug	L	Linear	FC	Full capacity	0.1 (20)	0.1 (20)	0.1 (20)											
					1A 1-Step reduction	0.06 (20)	0.06 (20)	0.06 (20)											
					2A 2-Step reduction	0.03 (20)	0.03 (20)	0.03 (20)											
					3A 3-Step reduction	0.01 (20)	0.01 (20)	0.01 (20)											
					4A 4-Step reduction	0.006 (20)	0.006 (20)	0.006 (20)											
					5A 5-Step reduction	0.006 (20)	0.006 (20)	0.006 (20)											
Y	Special	Y	Special	YY	Special	Contact Valmet for Cv details													

- Rated Cv is different depending on the trim type and characteristic.
- Str. : valve stroke length(mm). It should be matched with actuator stroke length.

Angle Balanced, Cage Guided Type, Series AB

1.	2.	3.	4.	5.	6.	7.	8.	9.	10.	11.	12.	13.	14.	15.	16.	17.	18.	19.	20.	21.	22.
AB	03	C	W	A	J2	B	P1	X	BC	S1	R1	X	S	F	G	S	G	X	A	L	FC

VALVE CONSTRUCTIONS

1.	VALVE SERIES
AB	Angle Balanced, Cage guided type

2.	BODY SIZE			
02	2" / DN 50	03	3" / DN 80	
04	4" / DN 100	06	6" / DN 150	
08	8" / DN 200	10	10" / DN 250	
12	12" / DN 300	14	14" / DN 350	
16	16" / DN 400	18	18" / DN 450	
20	20" / DN 500	24	24" / DN 600	
28	28" / DN 700	30	30" / DN 750	
32	32" / DN 800	36	36" / DN 900	
YY	Special			

3.	PRESSURE RATING			
C	ASME Class 150	D	ASME Class 300	
F	ASME Class 600	G	ASME class 900	
H	ASME Class 1500	I	ASME Class 2500	
J	EN PN 10	K	EN PN 16	
L	EN PN 25	M	EN PN 40	
N	EN PN 63	P	EN PN 100	
B	EN PN 160	E	EN PN 250	
Y	EN PN 320			

4.	END CONNECTION
W	Flanged RF, ASME B16.5
Z	Ring joint flange, ASME B16.5
V	Socket welding, ASME B16.11
Q	Butt welding, ASME B16.25
Y	Special

5.	BONNET CONSTRUCTION	
	Bonnet type	Actuator connection
A	General	Applicable for VD_25/29/37
B	General	Applicable for VD_48/55
C	General	Applicable for VC_30, VB_32
D	General	Applicable for VC/VB_40/50
T	General	Applicable for VC/VB_60/70
E	Extension	Applicable for VD_25/29/37
F	Extension	Applicable for VD_48/55
G	Extension	Applicable for VC_30, VB_32
H	Extension	Applicable for VC/VB_40/50
U	Extension	Applicable for VC/VB_60/70
P	Cryogenic	Applicable for VD_25/29/37
Q	Cryogenic	Applicable for VD_48/55
R	Cryogenic	Applicable for VC_30, VB_32
S	Cryogenic	Applicable for VC/VB_40/50
V	Cryogenic	Applicable for VC/VB_60/70
Y	Special	Special

6.	BODY MATERIAL
J2	A216 gr. WCB
S6	A351 gr. CF8M
J4	A217 gr. WC6
CG	A217 gr. WC9
S1	A351 gr. CF3M
YY	Special

- Bonnet material is equivalent to Body material.

7.	MODEL CODE
B	Model B

* Face to face length according to ISA 75.08

* The body, bonnet, trim materials are subject to change as equivalent depending on detail design.

* See 'NelesGlobe Type code Instruction' for further options and explanations.

TRIM CONSTRUCTIONS

8.	PLUG MATERIAL	
	Material	Description
P1	CA15	General for carbon steel valve
T6	CF8M	General for stainless steel valve
P2	CA40	General for high temp. Cr-Mo Valve
S1	CF3M	
YY	Special	Special materials

9.	PLUG APPLICATION
X	Not applicable
A	Cobalt based alloy
Y	Special

10.	STEM MATERIAL	
	Material	Description
BC	630 SS	General for carbon steel valve
TC	316 SS	General for stainless steel valve
FC	316L SS	
VX	XM-19	

11.	SEAT TYPE
S1	Single metal seat
T1	Single soft seat
YY	Special

12.	SEAT / CAGE MATERIAL		
	Seat	Cage	Cage Guide
R1	CA15	CB7Cu-1 + HCr	CB7Cu-1 + HCr
R6	CF8M	CF8M + HCr	CF8M + HCr
P2	CA40	CA40	CA40
R3	CF3M	CF3M + HCr	CF3M + HCr
YY	Special	Special	Special

- CA15 / AISI 410 is general for carbon steel valve.

- CF8M / AISI 316 is general for stainless steel valve..

13.	SEAT APPLICATION
X	Not applicable
A	Cobalt based alloy
P	Insert PTFE
Q	Insert PTFE + Cobalt based alloy
Y	Special

OTHERS

14.	PACKING / BELLOWS TYPE
S	General packing
E	Low emission, Live loaded
C	Bellows Seal (316L SS, Formed)
Y	Special

15.	PACKING MATERIAL
G	PTFE + Carbon fiber
F	Graphite
T	PTFE V-Ring
C	PTFE + Carbon fiber (ATEX)
H	Hi-Graphite
Y	Special

16.	SEALS RING MATERIAL
G	PTFE + Graphite
H	PTFE + Graphite + Carbon
M	Graphite
N	Graphite + Metal
T	PTFE
Optional Seal Ring Material	
Y	Special

17.	GASKET MATERIAL
S	S/W gasket type, 316L SS + Graphite
L	S/W gasket type, 316L SS + PTFE
H	S/W gasket type, 316L SS + Hi-Graphite
Y	Special

18.	STUD / NUT MATERIAL
G	A193 gr. B7M / A194 gr. 2HM
D	A193 gr. B8M / A194 gr. 8M
K	A320 gr. B8M cl. 2 / A194 gr. 8M
H	A193 gr. B16 / A194 gr. 7
E	A453 gr. 660 / A453 gr. 660
Y	Special

19.	OPTIONS
X	Not applicable
E	Anti-erosion
L	Lub. & Isol. valve
W	Water seal
Y	Special

- * Face to face length according to ISA 75.08
- * The body, bonnet, trim materials are subject to change as equivalent depending on detail design.
- * See 'Neles Globe Typecode Instruction' for further options and explanations.
- * Round bar material such as AISI 410SS (for A743 gr. CA 15), AISI 316SS (for A351 gr. CF8M), SUS420J2 (for A743 gr. CA40) and AISI 630SS (for A747 gr. CB7Cu-1) can be used depending on manufacturing process.

TRIM TYPE & RATED Cv

20. Sign	TRIM TYPE	21. Sign	TRIM CHARACTERISTIC	22. Sign	RATED Cv																		
					Description	Body size and Stroke																	
						2"	Stk.	3"	Stk.	4"	Stk.	6"	Stk.	8"	Stk.	10"	Stk.	12"	Stk.	14"	Stk.	16"	Stk.
A	Balanced plug	L	Linear	FC	General / Full capacity	82	(40)	174	(50)	280	(50)	470	(60)	810	(70)	1250	(80)	1810	(120)	2530	(140)	2960	(160)
A	HT graphite seal plug			1A	General / 1-Step reduction	74	(40)	104	(50)	170	(50)	284	(60)	500	(70)	760	(80)	1100	(120)	1540	(140)	1780	(160)
A	HT metal seat plug			2A	General / 2-Step reduction	44	(40)	62	(50)	100	(50)	170	(60)	320	(70)	460	(80)	680	(120)	940	(140)	1080	(160)
A	Pilot balanced plug			3A	General / 3-Step reduction	26	(40)	40	(50)	64	(50)	100	(60)	200	(70)	280	(80)	420	(120)	580	(140)	660	(160)
				FT	Tendril 1 / Full capacity	52	(40)	102	(50)	160	(50)	290	(60)	460	(70)	630	(80)	980	(120)	1300	(140)	1580	(160)
				1T	Tendril 1 / 1-Step reduction	40	(40)	75	(50)	120	(50)	220	(60)	340	(70)	460	(80)	735	(120)	985	(140)	1145	(160)
				2T	Tendril 1 / 2-Step reduction	27	(40)	40	(50)	70	(50)	130	(60)	195	(70)	255	(80)	405	(120)	565	(140)	670	(160)
				3T	Tendril 1 / 3-Step reduction	10	(40)	21	(50)	46	(50)	75	(60)	105	(70)	140	(80)	240	(120)	310	(140)	410	(160)
				FM	Tendril 2 / Full capacity	50	(40)	100	(50)	155	(50)	280	(60)	425	(70)	590	(80)	920	(120)	1240	(140)	1530	(160)
				1M	Tendril 2 / 1-Step reduction	35	(40)	74	(50)	115	(50)	215	(60)	330	(70)	450	(80)	720	(120)	970	(140)	1130	(160)
				2M	Tendril 2 / 2-Step reduction	23	(40)	33	(50)	65	(50)	120	(60)	190	(70)	240	(80)	380	(120)	550	(140)	640	(160)
				3M	Tendril 2 / 3-Step reduction	8	(40)	18	(50)	38	(50)	67	(60)	100	(70)	130	(80)	220	(120)	290	(140)	390	(160)
		E	Equal %	FC	General / Full capacity	76	(40)	160	(50)	256	(50)	430	(60)	740	(70)	1140	(80)	1650	(120)	2300	(140)	2700	(160)
				1A	General / 1-Step reduction	46	(40)	98	(50)	156	(50)	260	(60)	450	(70)	680	(80)	1000	(120)	1400	(140)	1640	(160)
				2A	General / 2-Step reduction	28	(40)	60	(50)	94	(50)	156	(60)	270	(70)	410	(80)	640	(120)	840	(140)	980	(160)
				3A	General / 3-Step reduction	18	(40)	35	(50)	60	(50)	96	(60)	164	(70)	250	(80)	384	(120)	520	(140)	600	(160)
				FT	Tendril 1 / Full capacity	50	(40)	82	(50)	135	(50)	235	(60)	370	(70)	500	(80)	840	(120)	1110	(140)	1400	(160)
				1T	Tendril 1 / 1-Step reduction	35	(40)	58	(50)	95	(50)	170	(60)	265	(70)	370	(80)	600	(120)	785	(140)	1020	(160)
				2T	Tendril 1 / 2-Step reduction	20	(40)	35	(50)	58	(50)	100	(60)	170	(70)	225	(80)	355	(120)	480	(140)	600	(160)
				3T	Tendril 1 / 3-Step reduction	10	(40)	20	(50)	32	(50)	58	(60)	105	(70)	125	(80)	205	(120)	290	(140)	350	(160)
				FM	Tendril 2 / Full capacity	47	(40)	74	(50)	130	(50)	230	(60)	330	(70)	470	(80)	770	(120)	1050	(140)	1320	(160)
				1M	Tendril 2 / 1-Step reduction	33	(40)	56	(50)	92	(50)	165	(60)	245	(70)	330	(80)	570	(120)	720	(140)	960	(160)
				2M	Tendril 2 / 2-Step reduction	19	(40)	33	(50)	52	(50)	95	(60)	145	(70)	190	(80)	330	(120)	430	(140)	550	(160)
				3M	Tendril 2 / 3-Step reduction	8	(40)	16	(50)	25	(50)	52	(60)	80	(70)	110	(80)	190	(120)	270	(140)	295	(160)
Y	Special	Y	Special	YY	Special	Contact Valmet for Cv details																	

- Rated Cv is different depending on trim characteristic.
- Str. : valve stroke length(mm). It should be matched with actuator stroke length.

Angle Omega Trim, Multi-Stage Type, Series AM

1.	2.	3.	4.	5.	6.	7.	8.	9.	10.	11.	12.	13.	14.	15.	16.	17.	18.	19.	20.	21.	22.
AM	02	C	W	A	J2	B	P2	X	BC	S1	P2	X	S	G	G	S	G	X	A	E	FG

VALVE CONSTRUCTIONS

1.	VALVE SERIES
AM	Angle Omega trim, Multi-stage type

2.	BODY SIZE		
01	1" / DN 25	1H	1.5" / DN 40
02	2" / DN 50	03	3" / DN 80
04	4" / DN 100	06	6" / DN 150
08	8" / DN 200	10	10" / DN 250
12	12" / DN 300	14	14" / DN 350
16	16" / DN 400	18	18" / DN 450
20	20" / DN 500	24	24" / DN 600
28	28" / DN 700	30	30" / DN 750
32	32" / DN 500	36	36" / DN 900
YY	Special		

3.	PRESSURE RATING		
C	ASME Class 150	D	ASME Class 300
F	ASME Class 600	G	ASME Class 900
H	ASME Class 1500	I	ASME Class 2500
J	EN PN 10	K	EN PN 16
L	EN PN 25	M	EN PN 40
N	EN PN 63	P	EN PN 100
B	EN PN 160	E	EN PN 250
Y	EN PN 320		

4.	END CONNECTION
W	Flanged RF, ASME B16.5
Z	Ring joint flange, ASME B16.5
V	Socket welding, ASME B16.11
Q	Butt welding, ASME B16.25
Y	Special

5.	BONNET CONSTRUCTION	
	Bonnet type	Actuator connection
A	General	Applicable for VD_25/29/37
B	General	Applicable for VD_48/55
C	General	Applicable for VC_30, VB_32
D	General	Applicable for VC/VB_40/50
T	General	Applicable for VC/VB_60/70
E	Extension	Applicable for VD_25/29/37
F	Extension	Applicable for VD_48/55
G	Extension	Applicable for VC_30, VB_32
H	Extension	Applicable for VC/VB_40/50
U	Extension	Applicable for VC/VB_60/70
P	Cryogenic	Applicable for VD_25/29/37
Q	Cryogenic	Applicable for VD_48/55
R	Cryogenic	Applicable for VC_30, VB_32
S	Cryogenic	Applicable for VC/VB_40/50
V	Cryogenic	Applicable for VC/VB_60/70
Y	Special	Special

6.	BODY & BONNET MATERIAL
J2	A216 gr. WCB
S6	A351 gr. CF8M
J4	A217 gr. WC6
S6	A351 gr. CF8M
CG	A217 gr. WC9
YY	Special

7.	MODEL CODE
B	Model B

- * Face to face length according to ISA 75.08
- * The body, bonnet, trim materials are subject to change as equivalent depending on detail design.
- * See 'NelesGlobe Type code Instruction' for further options and explanations.

TRIM CONSTRUCTIONS

8.	PLUG MATERIAL	
P2	CA40	General for carbon steel valve
T6	CF8M + HCr	General for stainless steel valve
YY	Special	Special materials

9.	PLUG APPLICATION
X	Not applicable
A	Cobalt based alloy
Y	Special

10.	STEM MATERIAL	
BC	630 SS	General for carbon steel valve
TC	316 SS	General for stainless steel valve
VX	XM-19	

11.	SEAT TYPE
S1	Single metal seat
YY	Special

12.	SEAT / DISK STACK MATERIAL		
	Seat	Disk Stack	Cage Guide
P2	CA40	SUS 420J2	CA40
R4	CF8M	316L SS	CF8M + HCr
YY	Special	Special	Special

13.	SEAT APPLICATION
X	Not applicable
A	Cobalt based alloy
Y	Special

OTHERS

14.	PACKING / BELLOWS TYPE
S	General packing
E	Low emission, Live loaded
C	Bellows Seal (316L SS, Formed)
Y	Special

15.	PACKING MATERIAL
G	PTFE + Carbon fiber
F	Graphite
T	PTFE V-Ring
C	PTFE + Carbon fiber (ATEX)
H	Hi-Graphite
Y	Special

16.	SEAL RING MATERIAL
G	PTFE + Graphite
H	PTFE + Graphite + Carbon
M	Graphite
N	Graphite + Metal
T	PTFE
Optional Seal Ring Material	
Y	Special

17.	GASKET MATERIAL
S	S/W gasket type, 316L SS + Graphite
L	S/W gasket type, 316L SS + PTFE
H	S/W gasket type, 316L SS + Hi-Graphite
Y	Special

18.	STUD / NUT MATERIAL
G	A193 gr. B7M / A194 gr. 2HM
D	A193 gr. B8M / A194 gr. 8M
K	A320 gr. B8M cl. 2 / A194 gr. 8M
H	A193 gr. B16 / A194 gr. 7
E	A453 gr. 660 / A453 gr. 660
Y	Special

19.	OPTIONS
X	Not applicable
E	Anti-erosion
L	Lub. & Isol. valve
W	Water seal
Y	Special

- * Face to face length according to ISA 75.08
- * The body, bonnet, trim materials are subject to change as equivalent depending on detail design.
- * See 'Neles Globe Typecode Instruction' for further options and explanations.
- * Round bar material such as AISI 410SS (for A743 gr. CA 15), AISI 316SS (for A351 gr. CF8M), SUS420J2 (for A743 gr. CA40) and AISI 630SS (for A747 gr. CB7Cu-1) can be used depending on manufacturing process.

TRIM TYPE & RATED Cv

20. Sign	TRIM TYPE	21. Sign	TRIM CHARACTERISTIC	22. Sign	Description	RATED Cv															
						Body Size and Stroke															
						1" Str.	1-1/2" Str.	2" Str.	3" Str.	4" Str.	6" Str.	8" Str.	10" Str.	12" Str.	14" Str.	16" Str.					
U	Unbalanced plug	L	Linear	FG	Full capa. / Gas	8 (20)	18 (20)	30 (40)	62 (50)	96 (50)	168 (60)	290 (70)	440 (80)	640 (120)	880 (140)	1160 (160)					
A	Balanced plug			FL	Full capa. / Liquid																
A	HT graphite seal plug			1G	1-Step red. / Gas	5 (20)	12 (20)	20 (40)	40 (50)	60 (50)	100 (60)	180 (70)	270 (80)	400 (120)	530 (140)	700 (160)					
A	HT metal seat plug			1L	1-Step red. / Liquid																
P	Pilot balanced plug			2G	2-Step red. / Gas	3 (20)	8 (20)	12 (40)	26 (50)	40 (50)	64 (60)	110 (70)	160 (80)	240 (120)	320 (140)	420 (160)					
				2L	2-Step red. / Liquid																
				3G	3-Step red. / Gas	2 (20)	5 (20)	8 (40)	16 (50)	24 (50)	42 (60)	70 (70)	100 (80)	150 (120)	200 (140)	260 (160)					
				3L	3-Step red. / Liquid																
		E	Equal %	FG	Full capa. / Gas	5 (20)	10 (20)	18 (40)	38 (50)	60 (50)	104 (60)	176 (70)	268 (80)	390 (120)	540 (140)	710 (160)					
				FL	Full capa. / Liquid																
				1G	1-Step red. / Gas	2.5 (20)	6 (20)	11 (40)	24 (50)	36 (50)	64 (60)	108 (70)	164 (80)	236 (120)	328 (140)	430 (160)					
				1L	1-Step red. / Liquid																
				2G	2-Step red. / Gas	1.2 (20)	3 (20)	5 (40)	12 (50)	18 (50)	32 (60)	54 (70)	82 (80)	118 (120)	164 (140)	214 (160)					
				2L	2-Step red. / Liquid																
				3G	3-Step red. / Gas	0.6 (20)	1.5 (20)	2 (40)	6 (50)	9 (50)	16 (60)	27 (70)	40 (80)	60 (120)	82 (140)	106 (160)					
				3L	3-Step red. / Liquid																
Y	Special	Y	Special	YY	Special	Contact Valmet for Cv details															

- Rated Cv is different depending on trim type and characteristic.
- Str. : valve stroke length(mm). It should be matched with actuator stroke length.

13. GENERAL SAFETY WARNINGS AND DISCLAIMERS

General safety warnings

Lifting

1. Always use a lifting plan created by a qualified person to lift this equipment. Lifting guidance is provided in this IMO (Installation, Maintenance and Operation manual) to assist in lifting plan development. Think about the point center of gravity (CG) of the equipment being lifted. Make sure the CG is always under the central lifting point.
2. Valves may be equipped with lifting threads on the body or on the flanges. These are which are intended for use with the lifting plan.
3. Use only correct and approved lifting devices. Ensure that lifting devices and straps are securely attached to the equipment prior to lifting.
4. Check, that lifting devices are not damaged and in good condition with a valid check stamp prior to use.
5. Workers must be trained for lifting and handling valves.
6. Never lift an assembly by the instrumentation (solenoid, positioner, limit switch, etc.) or by the instrumentation piping. Straps and lifting devices should be fitted to prevent damage to instrumentation and instrumentation piping. Failure to follow the lifting guidance provided may result in damage and personal injury from falling objects.

Work activities on the valve

1. Wear your personal safety equipment. Personal safety equipment includes but is not limited to protective shoes, protective clothing, safety glasses, helmet, hearing protection and working gloves.
2. Always follow the local safety instructions in addition to the Valmet instructions. If Valmet instructions conflict with local safety instructions, stop work and contact Valmet for more information.
3. Before beginning service on the equipment, make sure that the actuator is disconnected from any kind of power source (pneumatic, hydraulic, and/or electric), and no stored energy is applied on the actuator (compressed spring, compressed air volumes, etc.). Do not attempt to remove a spring return actuator unless the stop screw is carrying the spring force.
4. Make sure that there is a LOTOTO (Lock Out / Tag Out / Try Out) procedure in place for the system in which the valve is installed and strictly follow it.
5. Always make sure that the pipeline is depressurized and in ambient temperature condition before maintenance work is started.
6. Keep hands and other body parts out of the flow port when the valve is being serviced and the actuator is connected to the valve. There is a high risk of serious injury to hands and/or fingers due to malfunction if the valve suddenly starts to operate.

General disclaimers

Receive, handle and unpacking

1. Respect the safety warnings above!
2. Valves are critical components for pipelines to control high pressure fluids and must therefore be handled with care.
3. Store valves and equipment in a dry and protected area until the equipment is installed.
4. Keep the original packaging on the valve as long as possible to avoid environmental contamination by dust, water, dirt, etc.

5. Remove the valve endcaps just before mounting into the pipeline.
6. FOR YOUR SAFETY IT IS IMPORTANT THE FOLLOWING PRECAUTIONS BE TAKEN PRIOR TO REMOVAL OF THE VALVE FROM THE PIPELINE OR BEFORE ANY DISASSEMBLY:
 - Be sure you know what fluid is in the pipeline. If there is any doubt, confirm with the proper supervisor.
 - Wear any personal protective equipment (PPE) required for working with the fluid involved in addition to any other PPE normally required.
 - Depressurize the pipeline, bring to ambient temperature, and drain the pipeline fluid.
 - Cycle the valve to relieve any residual pressure in the body cavity.
 - After removal but before disassembly, cycle the valve again until no evidence of trapped pressure remains.
7. The identification plate (nameplate, or engraved markings) on the valve gives the information of max. process conditions to the valve.
8. Temperatures and pressures must never exceed values marked on the valve. Exceeding these values may cause uncontrolled release of pressure and process fluid. Damage or personal injury may result.
9. Valmet valves typically are designed to be used in atmospheric conditions. Do not use valves under external pressurized conditions unless specifically designed and explicitly marked for this service.
10. Avoid Pressure shocks or water hammer. Systems with high pressure valves should be equipped with a bypass to reduce the differential pressure before opening the valve to avoid pressure shock.
11. Avoid thermal shock. High temperature, Low temperature and cryogenic valves should be operated in a way that limits the rate of increase or decrease in temperature. The valve should be thermally stabilized before being pressurized.
12. Materials of the valve are carefully selected for the process conditions. Changes to the process media can have a major impact on function and safety of the valve. Always confirm the materials are suitable for the service prior to installation.
13. As the use of the valve is application specific, a number of factors should be taken into account when selecting a valve for a given application. Therefore, some situations in which the valves are used are outside the scope of this manual.
14. It is the end user's responsibility to confirm compatibility of the valve materials with the intended service, however if you have questions concerning the use, application, or compatibility of the valve for the intended service, contact Valmet for more information.
15. Never use a valve with enriched or pure oxygen if the valve is not explicitly designed and cleaned for oxygen. Selected materials and design have a major impact on the safety to operate the valve with oxygen.
16. Valves intended for use in or with explosive atmospheres must be equipped with a grounding device and marked according ATEX (or equivalent international standards).

Maintenance

17. Respect the safety warnings above!
18. Plan service and maintenance actions, that spare parts, lifting devices and service personnel is available.

19. Maintain the valve within the recommended minimum maintenance intervals or within the recommended maximum operating cycles.
20. Always make sure that the valve and the pipeline is depressurized before starting any kind of maintenance work at a valve.
21. Always check the position of the valve before starting maintenance work. Follow the Lock out /tag out (LOTO) rules at the site before starting any maintenance activity.
 - See IMO for the correct stem position.
 - Consider that the positioner may give the wrong signals.
22. Sealing materials (soft sealing parts) should be changed when the valve is maintained. Always use original equipment manufacturers (OEM) spare parts to ensure proper performance of the repaired valve.
23. All pressure containing parts must be inspected visually for damage or corrosion. Damaged parts must be replaced.
24. Valve pressure bearing parts and all internals must be inspected for corrosion or erosion which may result in reduced wall thickness on pressure bearing parts. Damaged pressure bearing parts must be replaced with original equipment manufacturer's (OEM) replacement parts or repaired to factory specifications by an authorized Valmet service partner in order to maintain the warrantee.
25. Do not use sharp tools, grinding machines, or files to work on functional surfaces such as sealing, seating or bearing surfaces as this can damage these surfaces.
26. Do not weld on pressure bearing parts without an ASME and PED qualified procedure and personnel.
27. Pressure bearing parts of valves in high temperature applications must be carefully examined for the effects of material creep and fatigue.
28. Make sure that the valve is positioned in the correct flow direction into the pipeline.
29. If the valves are marked to be suitable for explosive atmospheres, the correct function of the discharging device must be tested before returning to service.
30. Always work in a clean environment. Avoid getting particles inside the valve due to machining, grinding, or welding nearby.
31. Never store a maintained valve without flow port protection.
32. When pressure testing valve seats, never exceed the maximum operating pressure of the system or the maximum shut-off pressure marked on the valve identification plate.
33. Actuator mounting and unmounting:
 - Before installing the actuator on to the valve, be sure the actuator is properly indicating the valve position. Failure to assemble these to indicate correct valve position may result in damage or personal injury.
 - When installing or removing a linkage kit, best practice is to remove the entire linkage assembly, including couplings which may fall off the valve during lifting or when position changes.
 - Mounting sets have been designed to support the weight of the Valmet actuator and recommended accessories. Use of the linkage to support additional equipment or additional weight such as people, ladders, etc. may result in equipment damage or personal injury.
34. The valve should be installed between flanges using appropriate gaskets and fasteners that are compatible with the application, and in compliance with applicable piping codes and standards. Center the gaskets carefully when fitting the valve between the flanges. Do not attempt to correct pipeline misalignment by means of the flange bolting.
35. Repairs on valves for special service like Oxygen, Chlorine, and Peroxide, have special requirements.
 - Parts must be cleaned appropriate to the service and protected from contamination prior to assembly.
 - Assembly areas and tools must be clean and dry to prevent contamination of the parts during assembly.
 - Test equipment must be clean and dry to prevent contamination during testing. This includes the test equipment internals that may allow particles or other contamination into the test fluid during the test.
 - Lubrication shall be used only if specifically required in the instructions. Where lubrication is required, the lubricant must be approved for the service by the end user.

Valmet Flow Control Oy

Vanha Porvoontie 229, 01380 Vantaa, Finland.

Tel. +358 10 417 5000.

www.valmet.com/flowcontrol

Subject to change without prior notice.

Neles, Neles Easyflow, Jamesbury, Stonel, Valvcon and Flowrox, and certain other trademarks, are either registered trademarks or trademarks of Valmet Oyj or its subsidiaries in the United States and/or in other countries.

