

Stonel™ Axiom™ advanced  
explosionproof, nonincendive &  
intrinsically safe  
on/off valve controller  
AN/ANX series





## Advanced performance

The Stonel Axiom series offers unmatched reliability using non-contact position sensing with solid state electronics and contaminant-tolerant pneumatic control. Coupled with its space-efficient design, corrosion resistance and networking/wireless capability, the device offers unrivaled convenience and cost-saving benefits in hazardous and general purpose process applications.

### Exceptional reliability

The proven technologies combined with efficient design and durable materials, delivers long life and exceptional performance.

- Survives harsh conditions
- Tolerates air contaminants
- Provides solid state position-sensing

### User-friendly advanced technology

Designed with the user in mind, the Axiom offers the utmost in ease and convenience.

- Rapid enclosure entry
- Easy configuration
- Convenient wiring access
- Stonel Wireless Link app set up

### Universal application

The strategic engineering reduces inventory and ensures universal adaptability in many applications and environments.

- Universal voltage capability
- Selectable SR/DA action
- Direct actuator attachment

### Space efficient design

The unit encloses all electrical components in a compact package. The automated valve spacing envelope is minimized without compromising performance or maintainability.

- Requires less than 5" of total clearance
- Additional 2" clearance for cover removal
- No tools for cover removal

Stonel Axiom

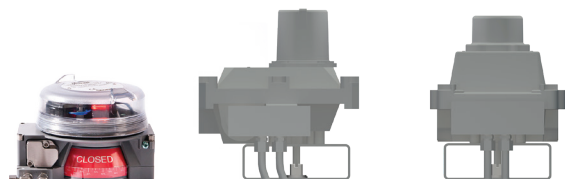

## Features

### 1. Impact-resistant cover

Cover screws off for rapid entry without tools and withstands high-pressure wash downs and typical process environment corrosives.

### 2. Universal voltage solenoid system

Operates from 24 VDC – 250 VAC at extended temperature range and features manual override. Single or dual coil available.

### 3. Convenient settings

Touch pad enables position settings to be conveniently locked in. Switch settings remain in place during power cycling.

### 4. Fully sealed module

Solid state, fully potted sensors provide protection against residual moisture, vibration, and corrosives.

### 5. High flow pneumatic valve

5-way, 2-position valve operates on standard plant air. Rebreather prevents ingestion of contaminated air into actuator.

### 6. High visibility indication

Mechanical and electronic indication confirms open and closed position. Intense LEDs display position status from a distance (clear cover option) and when cover is removed the visibility is useful for commissioning and troubleshooting.

### 7. Exceptional long life

Magnetic position sensor has no bushings or shafts to wear out, delivers reliable performance, and is unaffected by actuator shaft wear.

### 8. SR/DA plug

Plug positions into designated port to enable spring return or double-acting operation.

### 9. Direct actuator attachment

Compact mounting manifold system requires less space and wiring, connects to VDI/VDE 3845 (NAMUR) actuators and adapts to spring return or double-acting actuators.

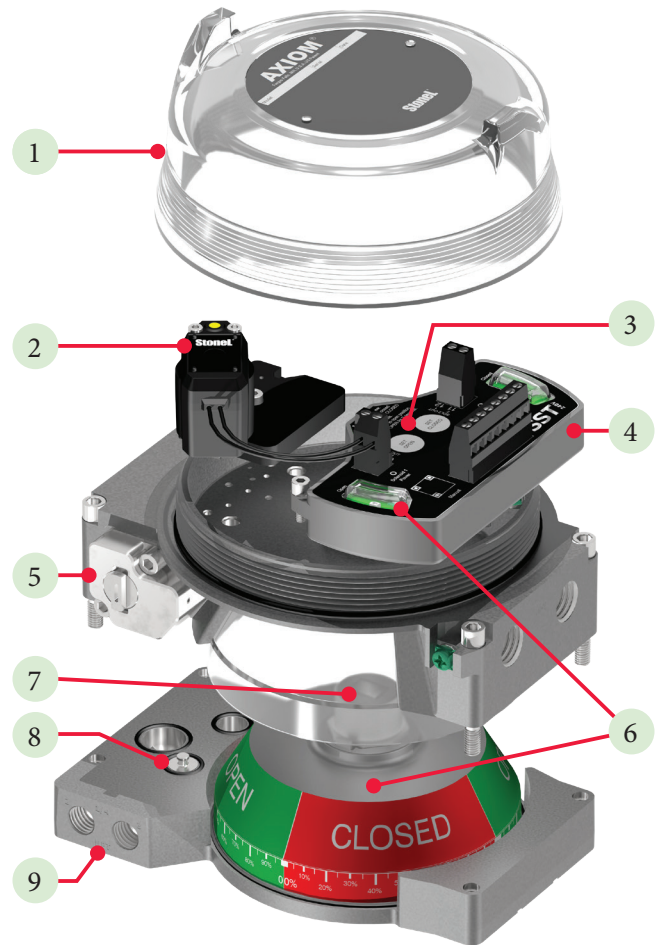

## Proven performance in process industries

- Chemical
- Oil and gas
- Pharmaceutical and biotech
- Food and beverage
- Marine
- Offshore service vessels (OSV)
- Biofuels
- And more...

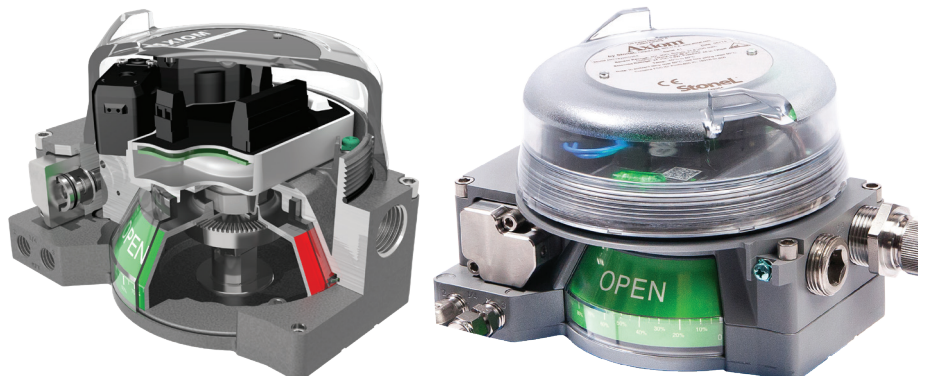

## Pneumatic control

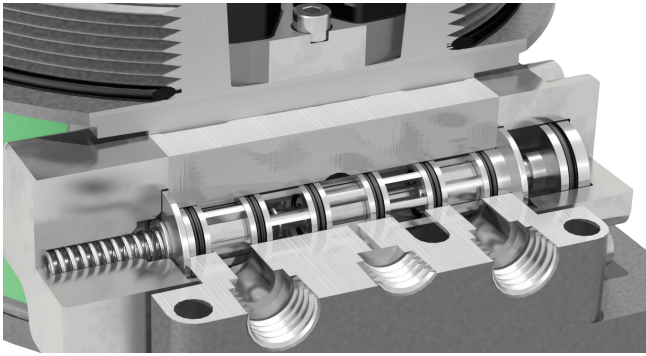

The Axiom's pneumatic valve system consists of a low-power pilot that drives the main high-flow spool valve. Pilots may be selected for conventional or bus networking applications. Both stages of the pneumatic valve system have been designed for long life, high tolerance to air line contaminants, and ease of maintenance should components become fouled. Pilots are automatically associated with the appropriate function selected.

### Special features

- Solenoid pilot and main spool design offer long life, exceptional tolerance to dirty air, and tight shut-off.
- Universal voltage solenoid system may be used for standard AC or DC applications.
- Five-way, two-position spring return configuration may be used for either single- or double-acting actuators. Dual coil shuttle piston versions are also available for fail-in-last position.
- Rebreather channels exhausted air from pressurized side of actuator into spring side, preventing ingestion of contaminated air from the environment that may corrode springs or actuator internals.
- Pneumatic manual override is conveniently located on top for easy access.



### Single or dual pilot configuration

The Axiom is available in either single or dual pilot configurations. Dual pilot options are available for shuttle piston, fail-in-last position applications. Several external manual override options are also readily available. For special valve configurations with non-standard manual override features, please consult factory.



### General pneumatic valve specifications

Valve design	Pilot operated spool valve	
Configuration	Single pilot	5-way, 2-position, spring return
	Dual pilot	5-way, 2-position, shuttle piston
Flow rating	0.8 Cv 1.2 Cv	
Axiom porting	1/4" NPT (0.8 Cv) 3/8" NPT (1.2 Cv)	
Manifold porting	1/4" NPT	
Operating pressure	45 psi to 120 psi (3.1 to 8.2 bar)	
Operating temperature	-40° C to 80° C (-40° F to 176° F)	
Operating life	1 million cycles	
Manual override	Internal momentary Optional external momentary available Optional external latching available	
Materials of construction	Spool Body Seal spacers Spool seals O-rings End-caps and fasteners	Nickel plated aluminum Epoxy-coated anodized aluminum Polysulfone Nitrile compound Nitrile compound Stainless steel

### Solenoid coil specifications

<b>35</b>	Operating voltage Power consumption	20 - 250 VAC; 20 - 55 VDC 12 mA @ 20 - 250 VAC (1.0 watts typical) 20 mA @ 20 - 55 VDC (0.5 watts typical)
	Filtration requirements	50 micron
<b>35 with conduit option 18 (8-pin micro)</b>	Operating voltage Power consumption	20 - 60 VAC; 20 - 55 VDC 12 mA @ 20 - 60 VAC (1.1 watts typical) 20 mA @ 20 - 55 VDC (0.5 watts typical)
<b>45</b>	Operating voltage Power consumption Filtration requirements	18 - 28 VDC 0.5 watts @ 12 VDC; 1.0 watt @ 24 VDC 50 micron
<b>92 &amp; 97</b>	Operating voltage Power consumption Filtration requirements	24 VDC 0.5 watts 50 micron

## Manifold and mounting system

The Axiom is designed to readily adapt to most quarter-turn actuators. The mounting manifold system combines the mounting base and pneumatic manifold to minimize space and simplify installation. It attaches the Axiom directly to the actuator and ports air from the pneumatic valve to the actuator.

Included in the manifold system are:

1. Actuator shaft adaptor and fastener.
2. Epoxy-coated anodized aluminum mounting plate manifold with o-rings and stainless steel fasteners.
3. Pneumatic plug for SR/DA configuration.

The manifold system readily adapts to VDI/VDE 3845 sizes 1, 2 and 3. Special variations may be made for sizes 3, 4 and non-standard quarter-turn actuator mounting patterns.

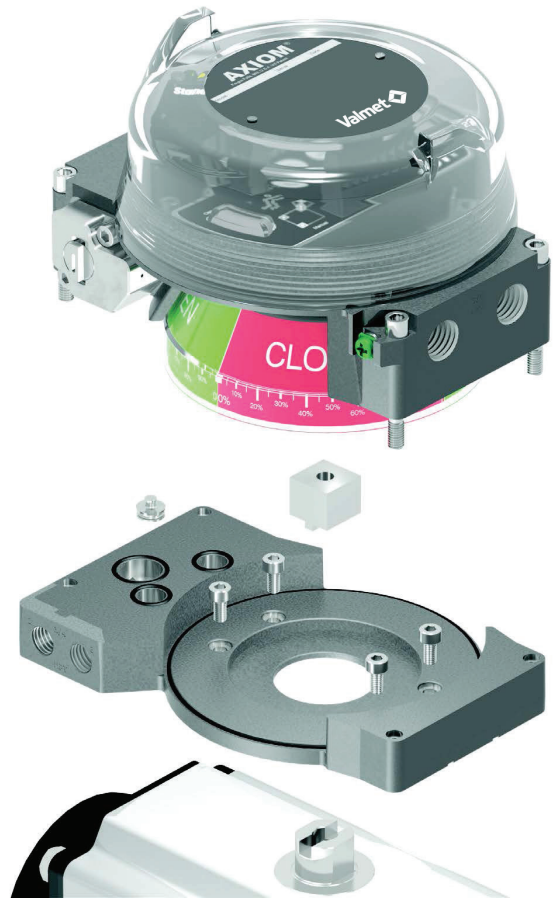

The mounting manifold system is specified and sold separately. Kits are specific to actuator manufacturer.

## Single or double-acting configuration

The same Axiom model is suitable for both single-acting/spring return (SR) and double-acting (DA) actuators. The standard rebreather capability for single-acting/spring return is built in. Field configuration may be made

by conveniently removing and reinserting the plug for the appropriate actuator type. For rebreather to function properly, both manifold ports must be tubed to the actuator.

Spring return actuator

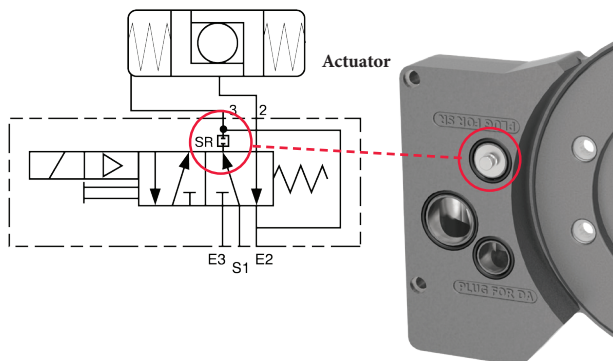

Double-acting actuator

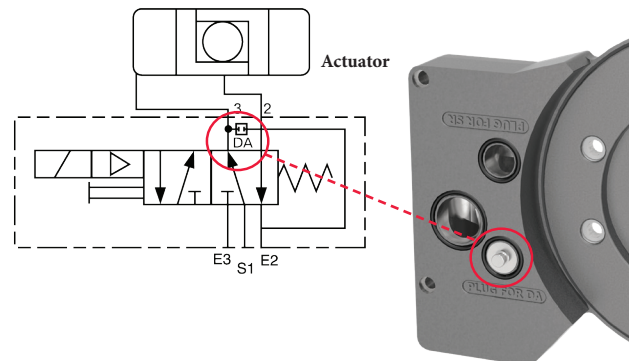

## Sensing and communication module

### Switching and sensor specifications

SST NO sensor (35S & 35W)	
Configuration	(2) NO 2-wire solid state sensors
Voltage range	20 - 250 VAC/VDC 8 - 75 VDC; 20 - 60 VAC [35S with conduit option 18 (8-pin micro)]
Minimum on current	2.0 mA
Maximum continuous current	0.1 amps
Typical leakage current	AC circuits 0.35 mA DC circuits 0.25 mA
Typical voltage drop	6.5 volts @ 10 mA 7.2 volts @ 100 mA
Circuit protection	Protected against short circuits and direct application of voltage with no load.

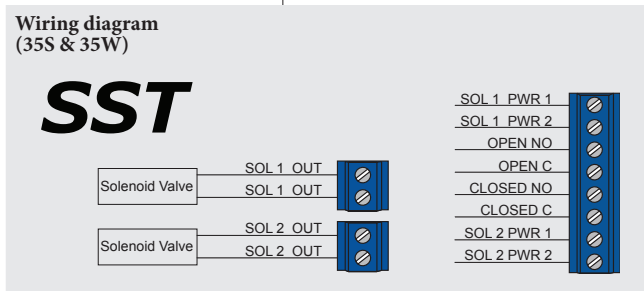

### Switching and sensor specifications

NAMUR sensor (45S)		
Configuration	(2) NAMUR sensors (EN 60947-5-6; IS)	
Voltage range	5 - 25 VDC	
Current ratings	Target present	current < 1.0 mA
	Target absent	current > 2.1 mA

Use with intrinsically safe repeater barrier. NAMUR sensors conform to EN 60947-5-6 standard.

Intrinsically safe solenoid coil	
Voltage	12 - 32 volts from output of solenoid barrier to coil*

\*Note: Use of an intrinsically safe solenoid barrier with internal impedance, or end-to-end resistance, of  $\leq 500$  ohms required for proper solenoid coil operation.

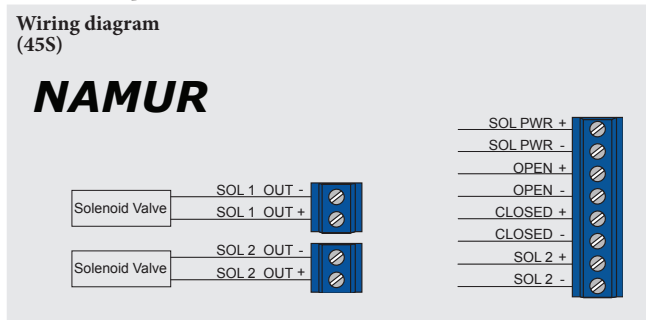

### Valve Communication Terminal (VCT) specifications

DeviceNet™ communication (92S & 92W)	
Communication protocol	DeviceNet™
Configuration	(2) Discrete inputs (sensors) (1) Auxiliary analog input (4-20 mA) (2) Discrete outputs (solenoids)
Input voltage	11 - 25 VDC via DeviceNet™ network
Output voltage	24 VDC
Analog input impedance	254 ohms
Quiescent current	No analog input, no outputs energized: 35 mA @ 24 VDC; 57 mA @ 11 VDC
Maximum output current	150 mA (all outputs combined)
Default address	63 (software assigned)
Default baud rate	125K (software selectable 125K, 250K or 500K baud)
Messaging	Polling, cyclic and change of state
DeviceNet™ type	100

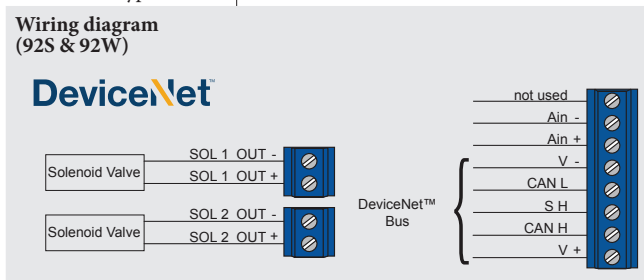

### Valve Communication Terminal (VCT) specifications

AS-Interface communication (97S, 97W, 98S & 98W)	
Communication protocol	AS-Interface v3.0 (97S & 97W) ASi-5 (98S & 98W)
Configuration	(2) Discrete inputs (sensors) (2) Auxiliary discrete inputs (2) Discrete outputs (solenoid)
Input voltage	26.5-31.6 VDC (AS-I voltage)
Output voltage	24 VDC (+/- 10%)
Quiescent current	35 mA (97S & 97W) 33 mA (98S & 98W)
Maximum output current	100 mA (all outputs combined)
Default address	0A (97S & 97W) 0 (98S & 98W)
ID/IO codes (97S & 97W)	ID = A; IO = 7; ID1 = F; ID2 = E (S-7.A.E.)
ID/IO codes (98S & 98W)	0xE22004

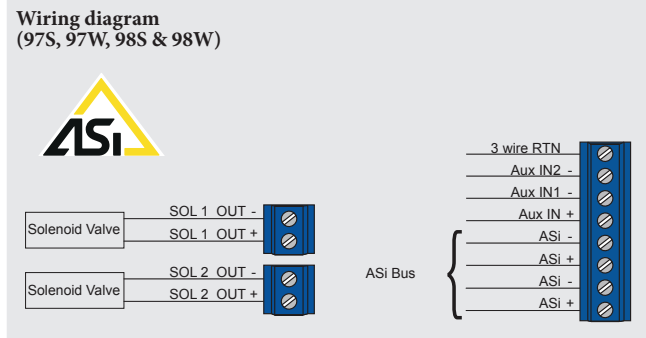

## Position sensor and module

The Axiom platform has all position sensing, communication or switching integrated into C-module. Users may set open/closed positions conveniently and accurately on all modules. And easy to view instructions, along with bold LED indication, are displayed on the module itself.

### Continuous sensing with open/closed settings

The C-module (continuous sensing) integrates a magnetic resistive sensor system to monitor exact valve position throughout the rotational range. Touch-sensitive or remote open and closed position setting along with microprocessor based operation make this state-of-the-art system convenient, reliable, and smart.

Position settings are made using the touch-sensitive buttons on the module's overlay. Simply operate the actuator to the open position (using standard internal manual override) and touch the SET OPEN button. Operate the actuator to the closed position and touch the SET CLOSED button. Position settings remain locked in when power is removed and reapplied.

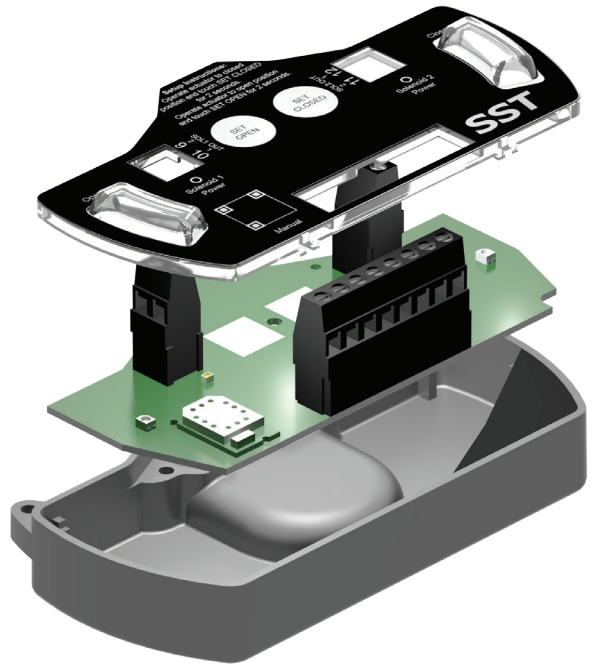

### Reliable position sensing

An extremely reliable solid state magnetic resistive (mag res) sensor detects the valve position by monitoring the orientation of a magnet attached to the actuator. This design is tolerant of lateral and vertical shaft movement, which may occur in heavily used actuators, without affecting rotational measurement.

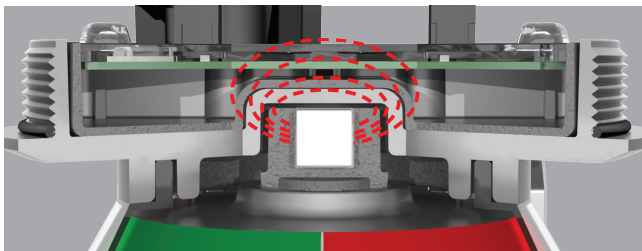

No cams, shafts or seals - offering exceptional vibration tolerance and nothing to wear out.

## Stonel Wireless Link capabilities

### Easily access hard-to-reach automated valves

Discover convenient remote access of your automated valves when you install an Axiom series featuring *Bluetooth®* technology. Devices may be remotely accessed from up to 50 meters depending on obstructions. Setting changes and solenoid control are enabled through the DeviceNet or AS-Interface network or by the AS-Interface power supply jumper.

### Special features

- Improve safety by easily controlling hard-to-reach automated valves without putting plant personnel at risk.
- Look up factory preset module code and serial number remotely.
- Electronically enter and store key automated valve system information including user tag and maintenance log.
- Reduce network commissioning time by accessing the VCT address to make changes.
- Reduce maintenance time by monitoring valve cycle count, cycle times, storing maintenance logs, and accessing multiple valves from one location.
- Conveniently retrieve installation manuals for additional technical information when connected to internet.

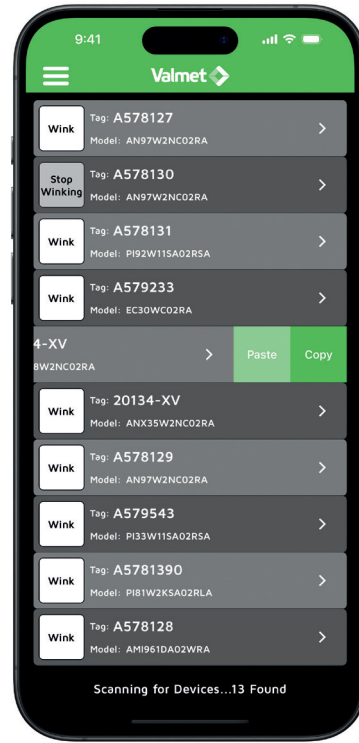

Customize the tag for a device, change the address, force the solenoids on or off, wink the device, and set the valve limits.

Operating information

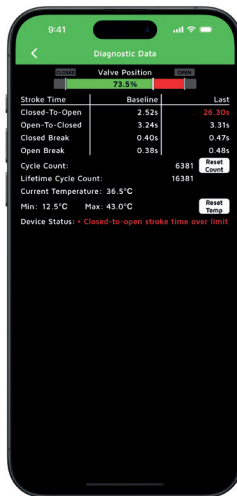

Store and view additional information about a specific valve, real time valve position, cycle count, cycle timing, current valve temperature, error status, and more.

Diagnostic data

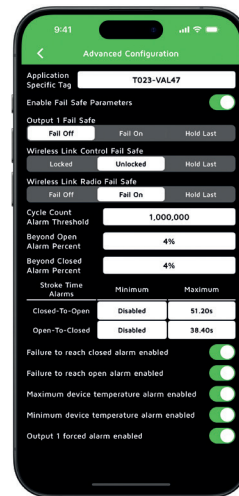

Apply-fail safe settings, cycle count alarms, stroke time thresholds, and more.

Advanced configuration

### Interfacing devices

Compatible with Android and iOS devices



### Stonel Wireless Link User guide is available

1. By selecting the Menu option in the app
2. At <https://www.valmet.com/flowcontrol/stonel-wireless-link-user-guide> and
3. By scanning this QR code

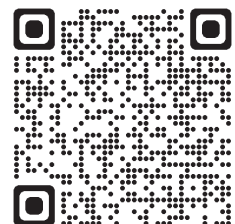



## Set up and operation

Devices with the wireless function are commissioned and set up identically to a standard unit. In addition, when powered up with a conventional power source or by the network, it may be accessed by standard Android and iOS devices. The Eclipse is accessed with the Bluetooth® protocol using the Stonel Wireless Link application.

Sequence of operation is:

1. Download the Stonel app onto your device (free of charge)
2. Start the application in your device
3. All energized wireless modules in range will come up
4. Push wink to positively confirm the device you have linked (device LEDs will flash)
5. Touch the specific ID tag to link with your handheld.

You can then monitor all status and diagnostic information and make necessary information changes to the free form fields at any time. Switch settings, address changes, and solenoid operation may be performed only if network- or power supply-enabled. Other information may also be added to the free form fields.

Specifications for Wireless Link	
Standard specifications apply to Axiom AN35W, AN92W, AN97W & AN98W	
Additional specifications for Wireless Link are as follows:	
Communication	Bluetooth® technology; single mode (not compatible with Bluetooth Classic)
Transmit power	4dBm or ~2.5 milliwatts
Data rate	1 Mbit/second; effective information transmit rate ~10 Kbits/second
Range	Up to 100 meters (330 feet) in free space. Range is reduced by obstructions between hand-held device and Wireless Link VCT. Line of site is not necessary.
Registrations	FCC, IC, CE
CE compliance	Exceeds industrial compliance standards
VCT identification	VCTs in range will be displayed
VCT link	One device accessed at a time between client (hand-held device) and server (VCT). Each server accessed by one client at a time
Application	Stonel Wireless Link
Hand-helds	Compatible with Android and iOS devices.

## Wireless Link enabled network

All settings and inputs are locked when standard network communication is functioning. For fast commissioning and asset management you can import and export electronic tags, model number, serial number, device address, descriptive fields, diagnostic data and more to and from standard CSV/Excel® files.

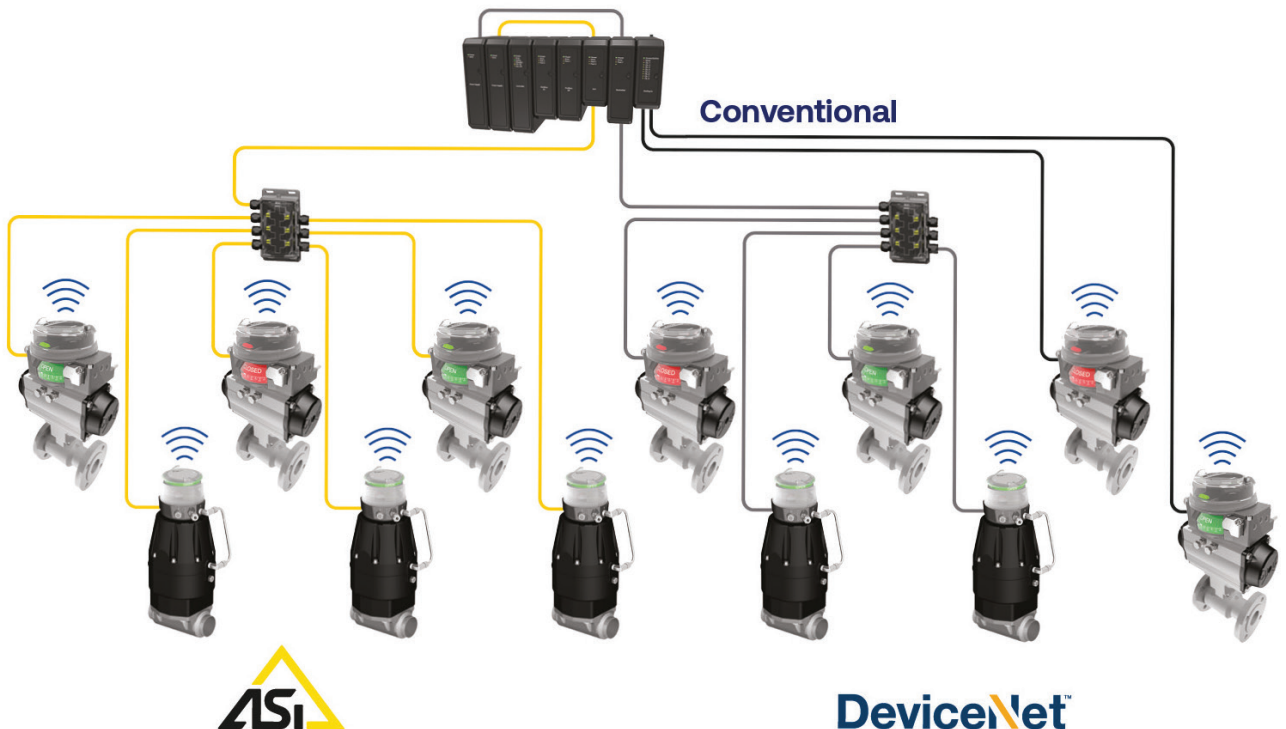

## Model selector

### SERIES

AN Nonincendive or intrinsically safe

### FUNCTIONS

#### Sensor/ switching modules

35S	SST Universal; 20 - 250 volt (NO sensor)
35W	SST Universal; 20 - 250 volt (NO sensor) with Wireless Link
45S	NAMUR module (EN 60947-5-6; I.S.)

#### Valve communication Terminals (VCTs)

92S	DeviceNet™
92W	DeviceNet™ with Wireless Link
97S	AS-Interface with extended addressing
97W	AS-Interface with extended addressing and Wireless Link
98S	AS-Interface (ASi-5)
98W	AS-Interface (ASi-5) with Wireless Link

### PNEUMATIC OVERRIDE / CV [standard pneumatic pilot and valve -40° C to 80° C]

#### For single pilot

1N	Internal momentary override only / 0.8 Cv
1M	External momentary & internal override / 0.8 Cv
1L	External latching & internal override / 0.8 Cv
1E	Internal momentary override only / 1.2 Cv
1Y	External momentary & internal override / 1.2 Cv
1G	External latching & internal override / 1.2 Cv
9N	No pneumatics

#### For dual pilot

2N	Internal momentary override only / 0.8 Cv
2M	External momentary & internal override / 0.8 Cv
2L	External latching & internal override / 0.8 Cv
2E	Internal momentary override only / 1.2 Cv
2Y	External momentary & internal override / 1.2 Cv
2G	External latching & internal override / 1.2 Cv

### ENCLOSURE

#### Epoxy-coated aluminum housing with clear cover

C	North American (NEC/CEC)
D	International (IEC)
B	Brazilian (INMETRO)

#### Epoxy-coated aluminum housing and cover

A	North American (NEC/CEC)
V	International (IEC)
G	Brazilian (INMETRO)

### CONDUIT/CONNECTORS

#### Standard

02	(2) ½" NPT
05	(2) M20

#### Mini-connectors

10	(1) 4-pin
11	(1) 5-pin
19	(1) 6-pin
20	(1) 7-pin
21	(1) 8-pin

#### Micro-connectors (M12)

13	(1) 4-pin
15	(1) 5-pin
17	(1) 6-pin
18	(1) 8-pin [Lower voltage range, check specifications]

### VISUAL INDICATOR [see chart on page 11]

RA	Red closed/green open	1A	Three-way 1	XA	Special
GA	Green closed/red open	2A	Three-way 2		

### Model number example

AN 35S 1L C 02 RA - OPTIONAL

#### MODEL NUMBER

Mounting hardware required and sold separately.

#### PARTNERSHIP ID

Some models may include 5-digit identification suffix.

### Model selector

#### SERIES

ANX Explosionproof, nonincendive or intrinsically safe

#### FUNCTIONS

Sensor/ switching modules

- 35S SST Universal; 20 - 250 volt (NO sensor)
- 45S NAMUR module (EN 60947-5-6; I.S.)

Valve communication Terminals (VCTs)

- 92S DeviceNet™
- 97S AS-Interface with extended addressing
- 98S AS-Interface (ASi-5)

#### PNEUMATIC OVERRIDE / CV [standard pneumatic pilot and valve -40° C to 80° C]

For single pilot

- 1N Internal momentary override only / 0.8 Cv
- 1M External momentary & internal override / 0.8 Cv
- 1L External latching & internal override / 0.8 Cv
- 1E Internal momentary override only / 1.2 Cv
- 1Y External momentary & internal override / 1.2 Cv
- 1G External latching & internal override / 1.2 Cv

For dual pilot

- 2N Internal momentary override only / 0.8 Cv
- 2M External momentary & internal override / 0.8 Cv
- 2L External latching & internal override / 0.8 Cv
- 2E Internal momentary override only / 1.2 Cv
- 2Y External momentary & internal override / 1.2 Cv
- 2G External latching & internal override / 1.2 Cv

9N No pneumatics

#### ENCLOSURE

Epoxy-coated aluminum

- A North American (NEC/CEC)
- V International (IEC)
- G Brazilian (INMETRO)

Stainless steel (CF3M)

- S North American (NEC/CEC)
- T International (IEC)
- M Brazilian (INMETRO)

#### CONDUIT/CONNECTORS

Standard

- 08 (2) ¾" NPT
- 09 (2) M25

#### VISUAL INDICATOR [see chart below]

- |                          |                |            |
|--------------------------|----------------|------------|
| RA Red closed/green open | 1A Three-way 1 | XA Special |
| GA Green closed/red open | 2A Three-way 2 |            |

Model number example

ANX 35S 1L A 08 RA - OPTIONAL

#### MODEL NUMBER

Mounting hardware required and sold separately.

#### PARTNERSHIP ID

Some models may include 5-digit identification suffix.

## Visual indicator designations

Clearly view valve position status from up to 75 feet with the Stonel Axiom's visual indicator. The indicator's rugged polycarbonate construction makes it resistant to physical damage and tolerant to most corrosives.



DESIGNATION	0°	90°
R	RED CLOSED	GREEN OPEN
G	GREEN CLOSED	RED OPEN
1	A ←→ B C	A ← B C
2	A ← B C	A → B C
X	Specialty configuration - please consult factory	

Specifications	
<b>Materials of construction</b>	
Housing and air manifold plate	Epoxy-coated anodized aluminum or CFM3 stainless steel
Visual indicator drum	Nylon
Visual indicator cover	Polycarbonate
Fasteners	Stainless steel
O-rings	Nitrile compound
Operating life	1 million cycles
Temperature range	-40 °C to +80 °C (-40 °F to +176 °F)
<b>Warranty</b>	
Sensing and communication module	Five years
Mechanical components	Five years
<b>Unit weights</b>	
Aluminum	AN 2.38 kg / 5.25 lb ANX 2.83 kg / 6.25 lb
CF3M stainless steel	ANX 7.78 kg / 17.15 lb
<b>Unit dimensions</b>	
Unit height	125 mm [4.90 in]
Cover removal clearance	214.00 mm [5.80 in]

<b>Position sensing</b>	
Accuracy	Within 1°
Repeatability	Within 1°
Setting buffer	4° from setpoint ( <i>Rotational distance from original setpoint where switch will energize on return stroke</i> )
Dead band	6° from setpoint ( <i>Rotational distance from original setpoint where switch will de-energize</i> )
Max rotational range	120°
<b>Ratings</b>	
Explosionproof ( <i>Ex d or Class I and II, Div. 1</i> )	All ANX models*
Nonincendive ( <i>Class I and II, Div. 2</i> )	All models*
Intrinsically safe ( <i>Ex ia Zone 0; Class I and II, Div. 1</i> )	Function 45S only*
<b>Enclosure protection</b>	
Type 4, 4X and 6	All models
Ingress Protection 66, 67, and 69K	All models
<b>Approvals*</b>	See manufacturer's website

\* Only models listed on Valmet official website are approved per specific rating.

## Dimensions

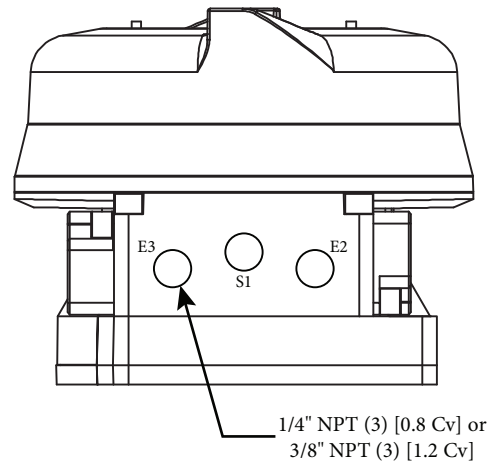
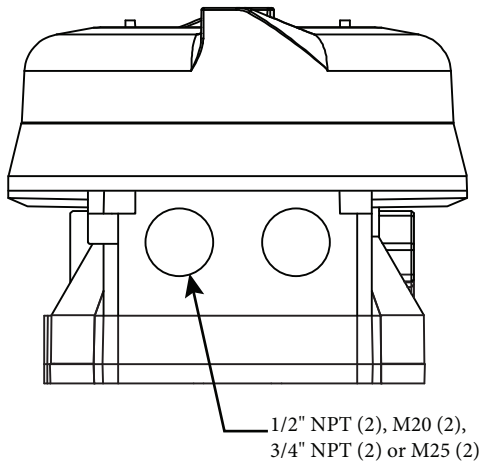
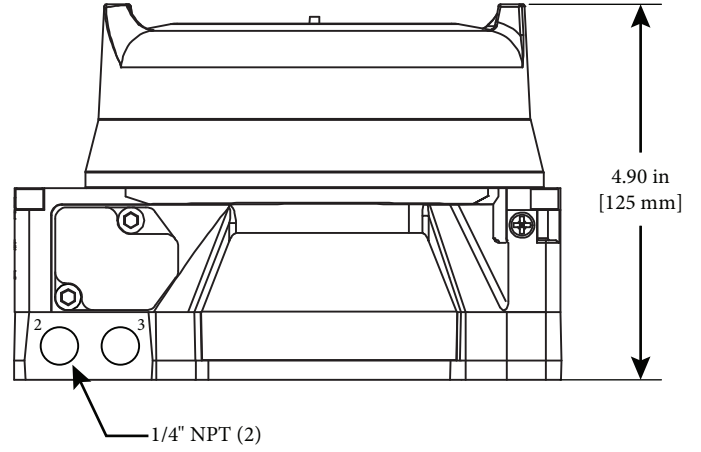
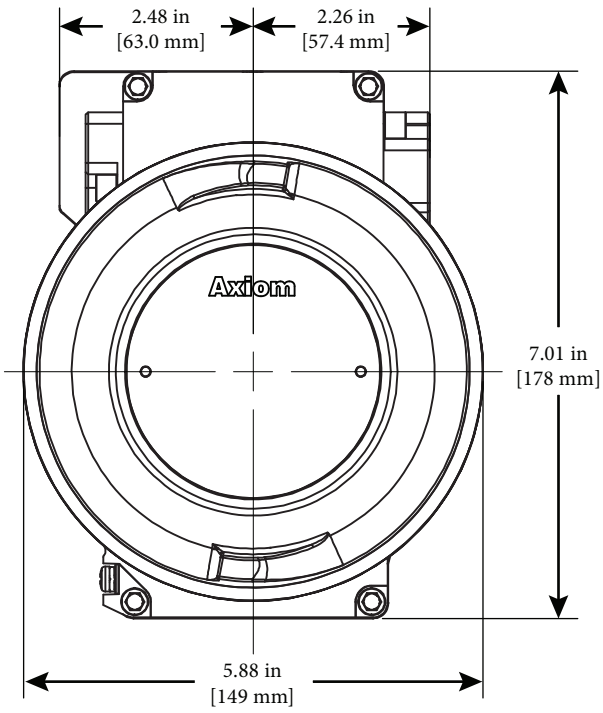

**Valmet Flow Control Inc.**

**Stonel product center**

26271 US Hwy 59, Fergus Falls, MN 56537 USA .

Tel. +1 218 739 5774.

**sales.stonel@valmet.com**

**valmet.com/flowcontrol**

Subject to change without prior notice.

Neles, Neles Easyflow, Jamesbury, Stonel, Valvcon and Flowrox, and certain other trademarks, are either registered trademarks or trademarks of Valmet Oyj or its subsidiaries in the United States and/or in other countries.

