

Spool valve VAQNCFC213

Installation, maintenance and
operating instructions

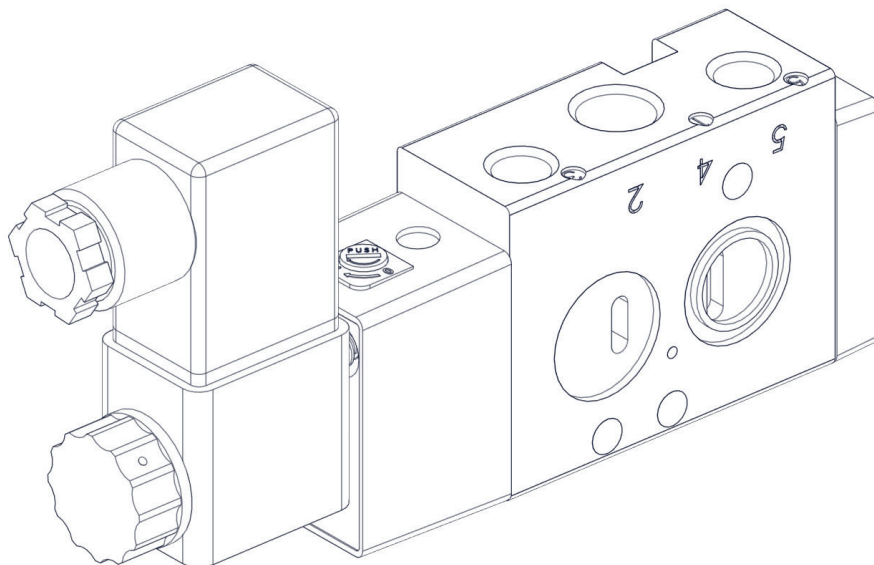

Table of contents

INTRODUCTION	3
Definitions	3
LABEL DESCRIPTION	3
INSTALLATION PROCEDURE	3
TECHNICAL SPECIFICATION	4
MAINTENANCE	4
DISASSEMBLY	4
Disassembly of VAQNCFC213	5
Exploded view	6
ASSEMBLY	7
CROSS-SECTION	8
Part list	9
PACKAGING & STORE	9
ASSISTANCE	9

READ THESE INSTRUCTIONS FIRST!

These instructions provide information about safe handling and operation of the valve.

If you require additional assistance, please contact the manufacturer or manufacturer's representative.

SAVE THESE INSTRUCTIONS!

Addresses and phone numbers are printed on the back cover.

1. INTRODUCTION

Thank you for choosing Valmet product. Each product is fully inspected after the production to offer you the highest quality. In order to fully utilize the product, we strongly recommend users to read this manual carefully and understood.

- This manual provides information on installation; operation and maintenance procedures and related instructions for the Neles brand VAQNCFC213 SPOOL VALVE.
- The aim of this literature is to support the use of products in correct manner, and all the technical information provided in the catalogue.
- The manual should be given to the end user.
- The manual can be changed or revised without any prior notice. Any changes in product's specification, structure, and/or any components may not result immediate revised version of the manual.
- The manual should not be duplicated or reproduced for any purpose without any consent of Valmet Flow Control INDIA PVT. LTD., INDIA.

MANUFACTURER WARRANTY

For the safety, it is vital to follow instructions in the manual. It is not Valmet liability for any damages which caused by users' negligence.

- It is not Valmet liability for any damages or accidents which resulted by any alteration or modification of the product and parts. If alteration or modification is necessary, please contact the Valmet directly.
- Valmet warrants the product from the date of original retail purchase of the product for one (1) year, except as otherwise stated.
- Valmet warranty will not cover the products that the product have been subjected to abuse, accident, alteration, modification, tampering, negligence, misuse, faulty installation, lack of reasonable care, repair or service in any way that is not contemplated in the documentation for the product, or if the model or serial number has been altered, tampered with, defaced or removed; damages that occurs in shipment, failure due to power surge, and cosmetic damage. Improper or incorrectly performed maintenance or report voids this Limited Warranty.
- For detailed warranty information, please contact: Valmet Flow Control INDIA PVT. LTD., Manapada road, Dombivli (E), Maharashtra, India, Pin - 421204

1.1 DEFINITIONS

WARNING:

IF NOT OBSERVED, USER INCURS A HIGH RISK OF SEVERE DAMAGE TO PRODUCT AND/OR FATAL INJURY TO PERSONNEL.



CAUTION:

IF NOT OBSERVED, USER MAY INCUR DAMAGE TO PRODUCT AND/OR INJURY TO PERSONNEL.



NOTE:

ADVISORY AND INFORMATION COMMENTS PROVIDED TO ASSIST MAINTENANCE PERSONNEL TO CARRY OUT MAINTENANCE PROCEDURES.

2. LABEL DESCRIPTION

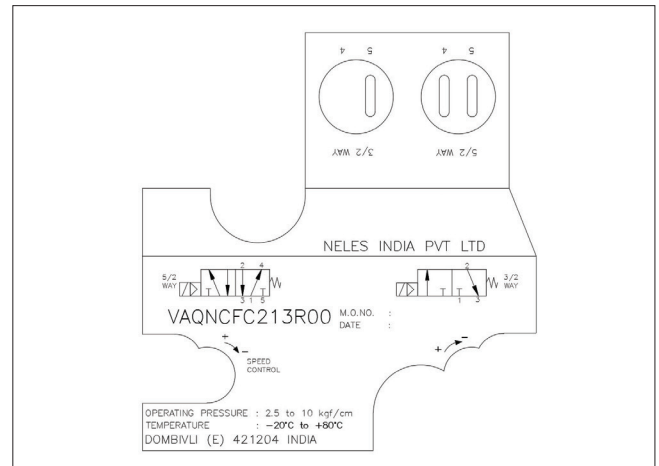

Label of the VAQ213NCFC-2R defines the precise feature. This description is written below the company logo and is as follow.

Model No.:	VAQNCFC – SPOOL VALVE 5/2 OR 3/2 converting Namur mounting valve with flow control.	
	2	1/4"
	04	2 Position, solenoid operated spring return.
Operating pressure	2.5 to 10 bar.	
Temperature	-20o C to +80oC	
M.O. NO.	Manufacturing order number.	
DATE	Date of manufacturing.	
Dombivli – 421204 INDIA Brief address.		

3. INSTALLATION PROCEDURE

CAUTION:

BLOW OUT AIR LINES AND FITTINGS BEFORE INSTALLATION.

- USE DRY AND OIL FREE AIR.
- DO NOT DISMANTLE THE VAQ213NC-FC WHILE OPERATION IS IN LINE.
- DO NOT ALLOW DIRTY AIR OR FLUIDS TO GET INTO THE VAQ213NC-FC. USE FILTER UNIT (FILTER SIZE 40MM, 3°C) FOR DUST AND MOISTURE REMOVAL.



NOTE:

- ENSURE THE INSTALLATION MEETS THE LEGAL AND REGULATORY REQUIREMENTS OF THE COUNTRY AND STATE OF USE.
- THE VAQ213NC-FC ASSEMBLY SHOULD BE LEFT IN THE ORIGINAL PACKING UNTIL IT IS REQUIRED FOR THE USE.

1. Hemp filaments, jute or even teflon ribbons are normally not required, As the part connections are accurately threaded. By chance, if any of these or any other tightening medium get into the operational area inside the VAQNCFC213, possible damage of the VAQNCFC213 could not be ruled out.

2. Clean all pipes and tube fittings thoroughly with suitable means. As even when brand new pipes are fitted, unclean interior are quite covered with dirt and dust.
3. Avoid impact on the VAQNCFC213. These may happen during transportation/ erection/ mishandling.

4. TECHNICAL SPECIFICATION

Model	VAQ213NCFC
Operation type	Internal Pilot operated
Type	5/2 and 3/2 single solenoid
Port	1/4" BSP / 1/4" NPT
Operating Pressure	2.5 to 10 kg/cm ²

5. MAINTENANCE

NOTE:

- THE VAQ213NC-FC MUST BE REMOVED FROM INSTALLATION PRIOR TO MAINTENANCE.
- ALL THE CONNECTIONS/PORTS HAVE TO BE DISCONNECTED PRIOR TO DISASSEMBLY.
- ALL THE MOUNTINGS, ACCESSORIES AND SPARE PARTS USED OR REPLACED MUST BE ORIGINAL FROM VALMET.

Valmet recommends "NELES M 55" grease for greasing.

- Apply the grease with soft brush or similar.
 - In case of any difficulty consult Valmet distributor.
1. Install, operate and maintain as per the instructions and recommendations of this manual.
 2. Any deviation from the above will cease the responsibilities of Valmet.

6. DISASSEMBLY

WARNING:

ALL ELECTRIC AND PNEUMATIC CONNECTIONS SHOULD BE REMOVED BEFORE STARTING DISASSEMBLY.



CAUTION:

IF NOT ODO NOT PLACE DISMANTLED PART ON ANY DIARY/WORK BENCH BUT KEEP IT ON CLEAN PAPER/CLOTH IN SAME SEQUENCE AS YOU HAVE DISMANTLED IT.



NOTE:

- IT IS ADVISABLE TO REPLACE ALL THE RUBBER PARTS USING GENUINE NELES SPARE KIT.
- NUMBERS IN PARENTHESES, () INDICATE THE BUBBLE NUMBER (REFERENCE NUMBER) USED ON THE NELES ASSEMBLY DETAILS AND PART LIST.

6.1 DISASSEMBLY OF VAQNCFC213

1. Remove coil nut (26), after that remove solenoid coil (24).

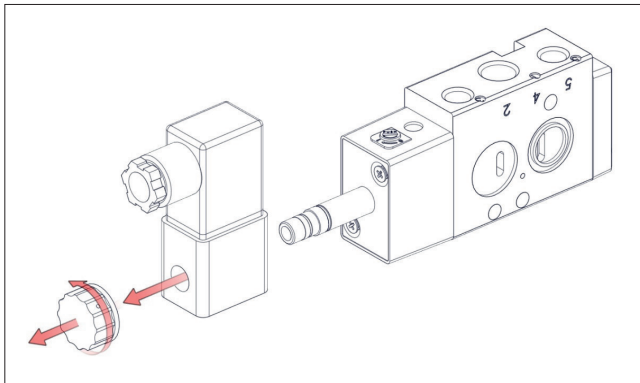

2. Remove the 2 screws (30) by loosening them from EL cover (2), Cover plate (5) and simultaneously remove guide plunger (9).

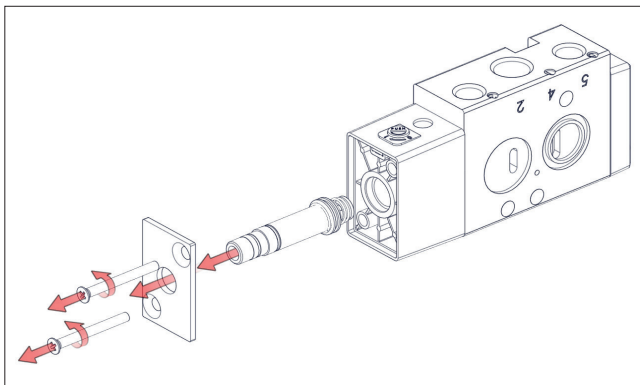

3. Remove EL cover (2) and separate the EL cover assembly.

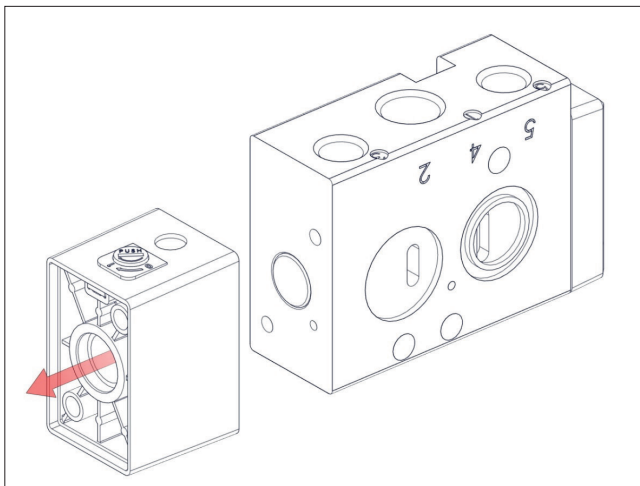

4. Take out EL cover assembly, remove MA (6), MA plate (7) O-ring (17) and MA spring (11) then remove O-ring (18) and helping piston (4) too.

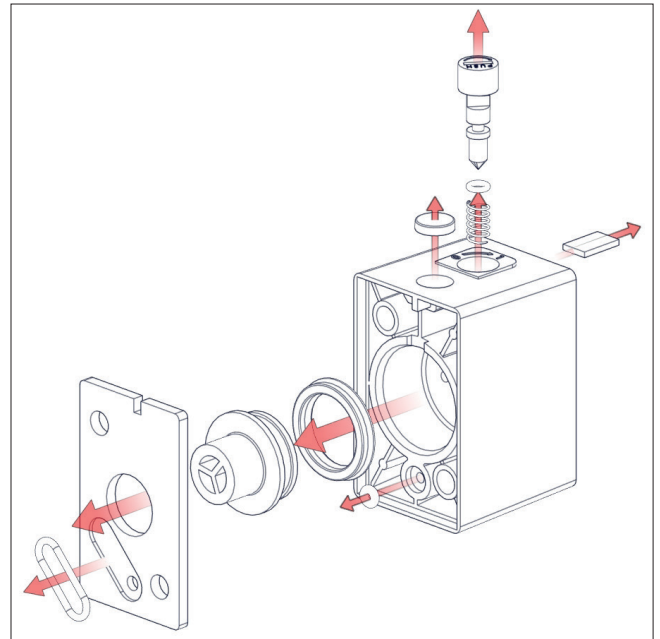

5. Separate out spring cover (10) and spring (12) by removing 2 bolt (28).

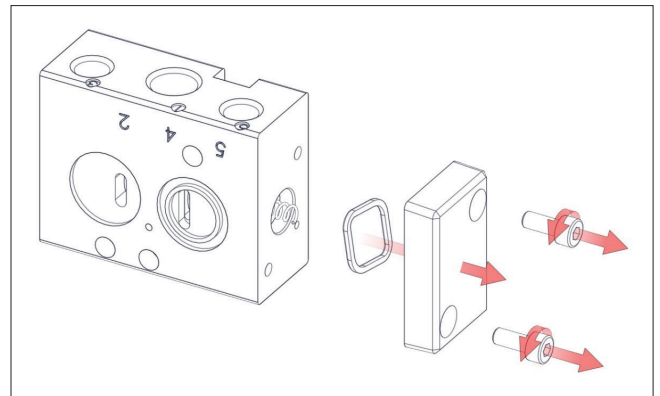

6. As both covers are removed, spool kit is disengaged, pull spool kit gently out of the valve body. Note: remove spool kit gently with non-metallic hammer, do not hammer heavily on the spool, by this spool may get jammed in bore during this operation.

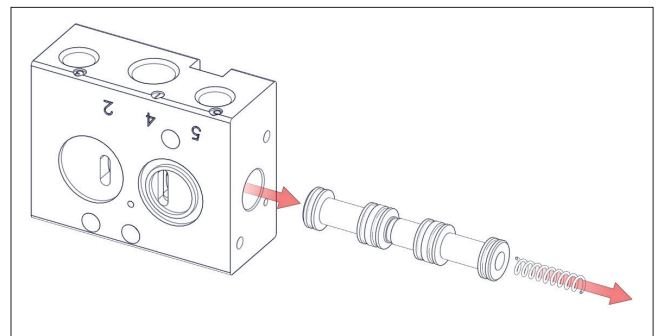

6.2 EXPLODED VIEW

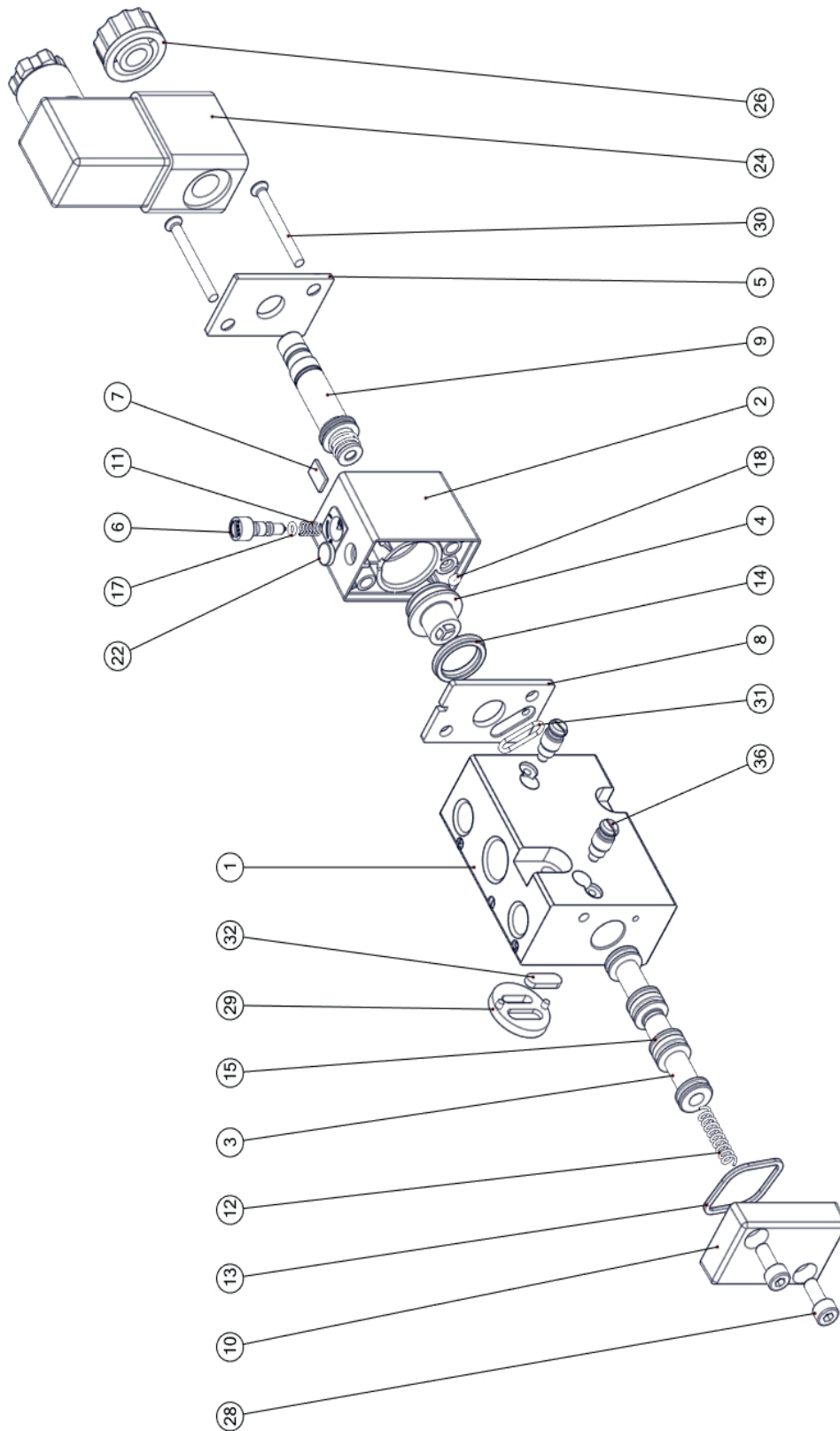

7. ASSEMBLY

NOTE:

• FOLLOW THE SEQUENCE AS GIVEN BELOW TO ENSURE PROPER ASSEMBLY.

1. Clean all parts with soap water and dry.
2. Apply a layer of Valmet recommended grease to the inner face of the body (1). (grease: NELES m 55).
3. Insert seal (14) on the spool (3)
4. While inserting spool into the body applies a thin layer of grease on the seal.
5. Insert the spool kit (3) into the body (1).

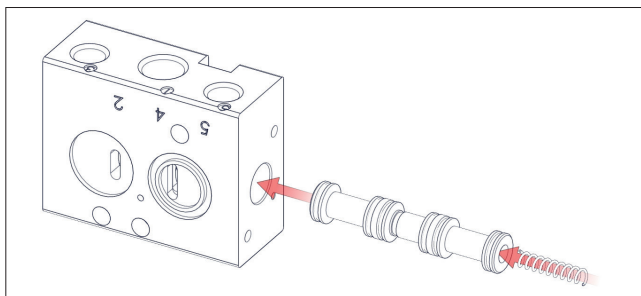

6. Insert the spring (12) and then insert spring cover (10) into the body (1) and screw it using screw (28).

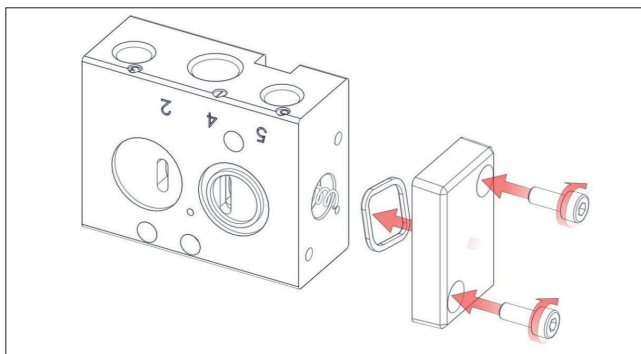

7. Insert the lip seal (14) on the piston (4) apply a thin layer of grease on the lip seal.
8. Separately make the assembly of EL cover, fit the MA (6) on EL cover (2) with O-ring (17) and spring (11) and fix it with MA plate (7). Finally fit filter (22) in given groove of EL cover (2).

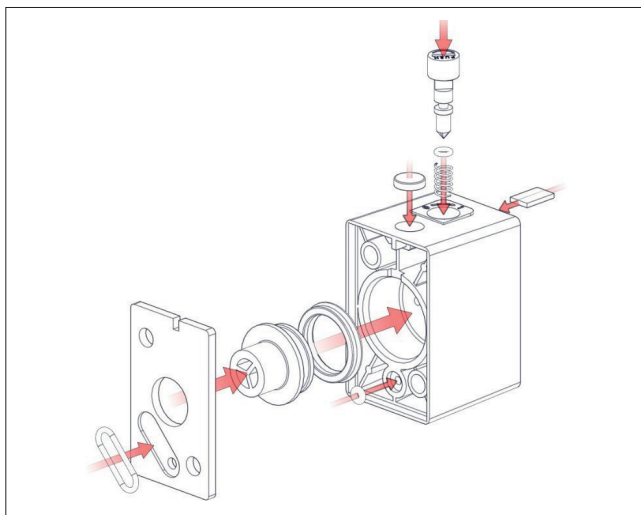

9. Place EL cover (2) on the body (1) and screw it with the help of 2 screw (30).

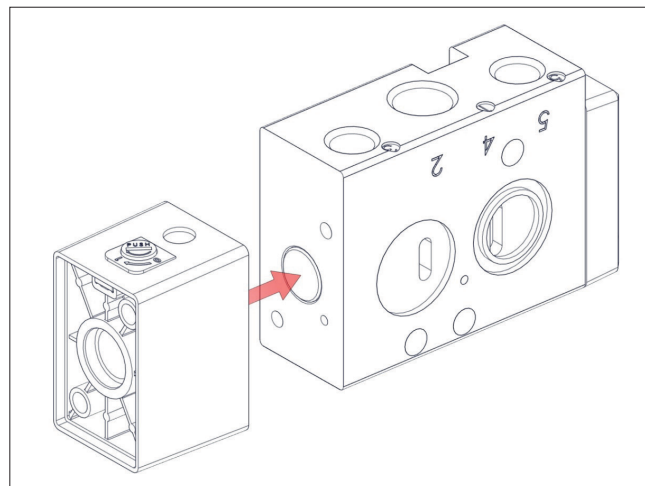

10. Insert guide plunger (9) and cover plate (5), screw it into EL cover (2) by using 2 screw (30).

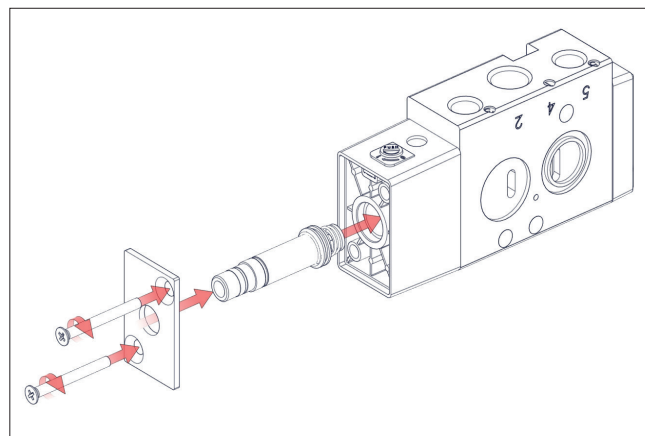

11. Insert solenoid coil (24) and screw it with the coil nut (26).

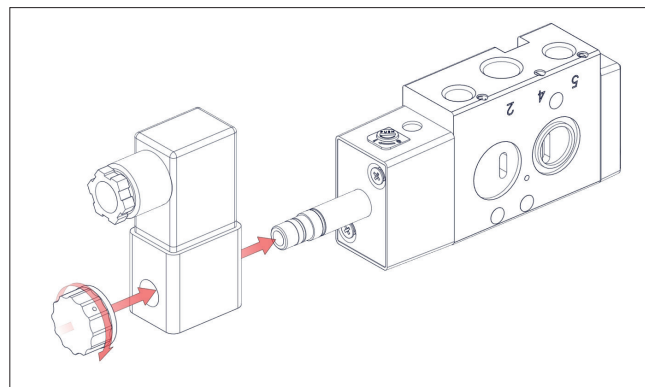

8. CROSS-SECTION

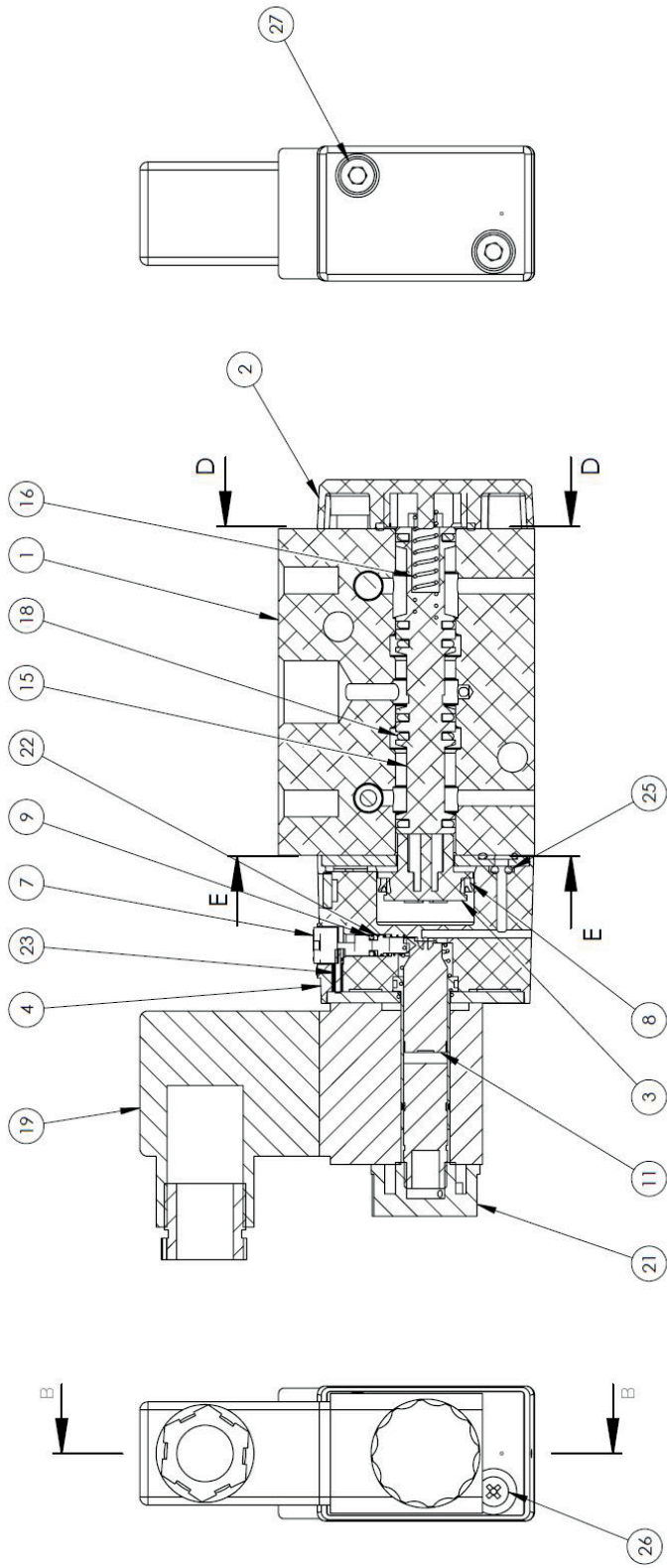

SECTION B-B

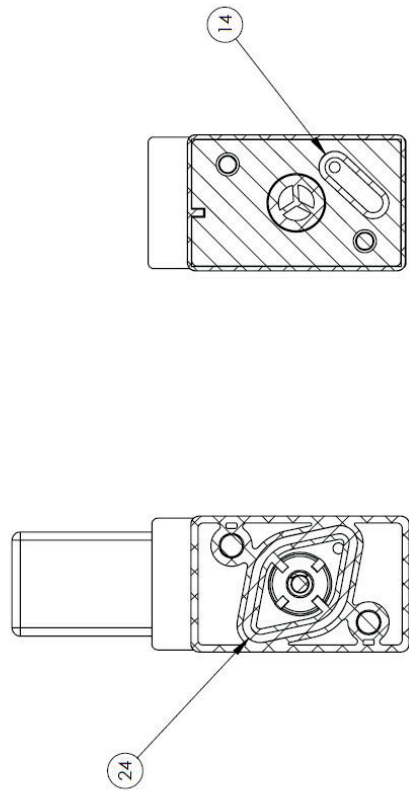

SECTION E-E

SECTION D-D

8.1 PART LIST

Sr. No.	Name	Quantity
1	BODY	1
2	EL COVER	1
3	SPOOL	1
4	HELPING PISTON	1
5	COVER PLATE	1
6	MANUAL OVERRIDE (MA)	1
7	LOCKING PLATE FOR MA	1
8	COVER PILOT	1
9	GUIDE PLUNGER	1
10	SPRING COVER	1
11	SPRING FOR MA	1
12	SPRING VAJ2	1
13	COVER SEAL	1
14	PISTON LIP SEAL	1
15	SEAL FOR SPOOL	6
17	ORING 2 x 1.25	1
18	ORING 1.80 x 1.40	1
19	M4 x 33 CSK FLAT HEAD SCREW	2
20	M4 x 10 HEXAGON SOCKET HEAD SCREW	2
21	BALL DIA 2	3
22	FILTER	1
23	DUST CAP FOR 1/4"	1
24	COIL	1
25	SOCKET FOR COIL	1
26	COIL NUT	1
27	DUST CAP FOR 1/8	2
28	M5 x 25 HEXAGON SOCKET HEAD	2
29	CONVERSION PLUG	1
30	M5 x 8 SOCKET SET SCREW	1
31	ORING 16.3 x 1.78	2
32	SEAL FOR CONVERSION PLUG	1
33	ORING 2.9 x 1.78	2
34	BALL DIA 3	2
35	SREW CYL32	2
36	DIN 84 M3 x 8 – 8 SCH	2

9. PACKAGING & STORE

1. When not in use, VAQNCFC213 ASSEMBLY should be kept in a sealed plastic bag in a cardboard box to prevent moisture or dust from contacting product.
2. VAQNCFC213 should be stored in a dry place free from water and dust.
3. Store at temperature between 40°F and 120°F (4°C and 49°C).
4. Locate in an area to avoid damage by impact.

10. ASSISTANCE

For technical questions or assistance, contact any authorized distributor of Valmet or:

For technical questions or assistance, contact any authorized distributor of Valmet Flow Control India Private limited. or:

Valmet Flow Control Oy

Vanha Porvoontie 229, 01380 Vantaa, Finland.

Tel. +358 10 417 5000.

www.valmet.com/flowcontrol

Subject to change without prior notice.

Neles, Neles Easyflow, Jamesbury, Stonel, Valvcon and Flowrox, and certain other trademarks, are either registered trademarks or trademarks of Valmet Oyj or its subsidiaries in the United States and/or in other countries.

For more information www.neles.com/trademarks

